

Environmental Mitigations & Works Specifications

Contents

1. Environmental Mitigations.....	3
2. Ecological Mitigations	3
3. Protection of Archaeology.....	3
4. Movement and use of Machinery	4
4.1. Vehicles	4
4.2. Route selection.....	4
4.3. Access track in “Good Condition”	6
4.4. Access track in “Bad Condition	7
4.5. Refuelling.....	8
4.6. General.....	8
5. Transportation of materials to Work Sites.....	9
5.1. Specification for Materials transport.....	9
6. Temporary Trackway.....	10
7. Bare Peat Stabilisation and Revegetation – Heather Brash.....	10
7.1. Environmental Mitigations.....	10
7.2. Supply of Heather Brash	11
7.3. Delivery of the heather brash.....	11
7.4. Marshalling of the individual bag drops.....	12
7.5. Spreading of material.....	13
7.6. Preparing Bags for removal by airlifting as underslung load	14
8. Application of Lime, Seed and Fertiliser	16
8.1. Environmental Mitigations.....	16
8.2. Materials.....	17
8.3. Storage and delivery of Materials.....	18
8.4. Methodology	18
9. Gully Blocking	18
9.1. General Environmental Mitigations for gully blocking.....	18

9.2.	Construction of dams at the Works Sites.....	19
10.	Gully Blocking - Timber Dams	20
10.1.	Environmental Mitigations.....	20
10.2.	Supply of Timber	20
10.3.	Construction of Timber Dams	20
11.	Gully Blocking - Leaky Timber Dams	24
11.1.	Construction of Leaky Timber Dams	24
12.	Gully Blocking – Stone Dams	27
12.1.	Environmental Mitigations.....	27
12.2.	Supply of Stone.....	27
12.3.	Construction of Stone Dams	27
13.	Peat Dams	33
13.1.	Environmental Mitigations.....	33
13.2.	Borrow Pits.....	33
13.3.	Archaeological Mitigations.....	34
13.4.	Peat dams in larger gullies.....	34
13.5.	Specification for Peat Dams.....	37
14.	Specification for Re-profiling gully systems up to and including 2m high.....	42
14.1.	Gully / hagg Dimensions.....	42
14.2.	Methodology	43
14.3.	Protecting the toe of the reprofiled slope.....	43
15.	Specification for Reprofiling slopes over 2m high but less than 3m.....	48
15.1.	Methodology	49
15.2.	Protecting the toe of the reprofiled slope.....	50
16.	<i>Sphagnum</i> and Dwarf Shrub Specification.....	51
16.1.	18.1 Environmental Mitigations	51
16.2.	Transporting Plants to the Work Sites	52
16.3.	Dwarf Shrub Plug Planting Specification	52
16.4.	Plug Plant Care Guidelines	53
16.5.	Planting Method.....	58

1. Environmental Mitigations

- 1.1. Materials stored on vegetation will not remain on the same area for more than two weeks to avoid shading out.
- 1.2. All works undertaken will comply with the codes of conduct for Operations on Sites of Special Scientific Interest, Water Catchment Land, Environment Agency Regulations, Regulations issued by Dept. of Environment, DEFRA.
- 1.3. All Waste materials will be removed from site.
- 1.4. Should ground conditions be such that the works represent an unacceptable risk of damage to the ground (i.e. if considered excessively wet or excessively dry) the works will be halted, temporarily, until conditions are assessed as appropriate for restart.

2. Ecological Mitigations

- 2.1. Any evidence of protected animal species within the works area observed during surveying or during the works themselves will be recorded and an exclusion zone established for any re-profiling, peat dams or channel blocking works.
- 2.2. Any works on the ground will only be undertaken between 15th August and 31st March (outside of bird breeding season), unless specifically agreed with Natural England (NE) and the landowner.
- 2.3. No works that require access to the ground will be undertaken during bird breeding activity. If MFFP is made aware by any stakeholder that bird nesting activity is occurring early or late, NE will be consulted before any further work is carried out.
- 2.4. Sensitive areas, such as Upland Flushes, Fens and Swamps as identified by the Priority Habitat Inventory, will be avoided by the works including during machine works, machine access routes and aerial load lifting works.
- 2.5. All persons working on site will follow biosecurity measures to prevent the spread of Avian Flu / other diseases. This will include disinfecting footwear with Virkon disinfectant before and after entering a site, and reporting of any diseased or dead animals.

3. Protection of Archaeology

- 3.1. Local HER records will be checked by a qualified archaeologist and a desk based assessment will occur in advance with regards to the works, in order to identify sensitive archaeological features.
- 3.2. If required ground survey will be carried out by a qualified archaeologist. Survey results will be used to describe the impact of proposed works on the historic environment, including adjacent monuments, donor sites, access routes etc.
- 3.3. The location and methods for works will then be selected to avoid or minimise risk of damage to archaeological features of interest.

- 3.4. Agreed standoffs will be adopted for any designated Scheduled Monuments or other important features.

4. Movement and use of Machinery

4.1. Vehicles

- 4.1.1. All vehicles (plant/machinery and vehicles) driving onto or across open moorland (blanket bog or dry heath) and away from existing established tracks will be low ground pressure of no greater than 3 psi when fully laden to prevent damage. Vehicles may include use of flotation tyres, wide bog tracks and/or dual-wheeled tractors.
- 4.1.2. Excavators used on work sites are anticipated to be between 4 and 8 tonnes in weight. Excavators will be tracked, fitted with suitably wide “bog” tracks and have a ground pressure of no greater than 3 psi, to spread the load across the ground surface and minimise risk of rutting or damage.
- 4.1.3. Wherever possible, biodegradable hydraulic oils will be used to minimise the risk of chemical spills on protected sites.
- 4.1.4. 4.1.4. Emergency spill kits will be carried for all vehicles at all times and use will be in accordance with the manufacturer’s instructions.
- 4.1.5. Where access points are on soft ground, bog mats will be used to protect the ground from disturbance.
- 4.1.6. Bog mats will be available on site with excavators, in the event that they are required, to reduce the amount of vehicle access on and off site.
- 4.1.7. If a vehicle did become stuck the operator must stop immediately, make the machine safe (e.g. drain fuel if necessary) and inform MFFP and Natural England. No recovery should be attempted until the relevant authorities have been contacted and a recovery plan has been agreed.

4.2. Route selection

- 4.2.1. A banksman will be available for access and egress, to walk at a safe distance in front of the machine.
- 4.2.2. Existing made tracks, where available, will be used to access onto the site. Vehicle access to sensitive moorland areas must be carefully managed and routes chosen so as not to cause damage to the designated features of the SSSI/SAC/SPA or rutting of the peat surface.
- 4.2.3. Chosen routes across open moorland will only be used if the ground is in good condition (with respect to access/tracking), or otherwise avoided, and alternative route will be selected from within the hatched area on the access maps. Should no access route in suitable good condition be found within the hatched area, works will halt and alternative access discussed and agreed with Natural England. Representative photographs of ‘good’ and ‘bad’ condition are shown below in Photos 1–4.

- 4.2.4. Vehicles will avoid crossing the sensitive areas, HER features, recently restored areas, where vegetation is newly established and vulnerable to disturbance (e.g. establishing nurse crop, or bryophyte cover with limited vascular plants, rewetting programmes – visible surface water, bog polls). Movement of machinery over previous cutting areas, sphagnum planting or other well-established revegetation works is considered non-damaging, unless visual assessment of ground conditions by MFFP consider it at risk.
- 4.2.5. Where vehicles are found to be causing disturbance to the surface or rutting occurs, passage over these areas will cease until the habitat has recovered.
- 4.2.6. Repeat vehicle movements along the same routes will be avoided.
- 4.2.7. Access will be restricted to periods where it can be anticipated that the ground is dry, firm or frozen, avoiding periods of wet weather.
- 4.2.8. Proposals will always aim to deliver all excavator works on a given site in one contract or phase where possible, to avoid the potential cumulative impact of additional use of vehicles.
- 4.2.9. Any sensitive or recently restored areas subsequently discovered whilst on the work site will be marked out and avoided. All markers will be removed when operations are complete.
- 4.2.10. At any point where ground or weather conditions deteriorate and lead to an unacceptable risk of damage, works will cease until such time as their resumption will not cause persistent tracks, disturbance or rutting.

4.3. Access track in “Good Condition”



Figure 1 Photo showing some compressed vegetation. There will be no persistent tracks visible after 12 months.



Figure 2 Photo showing some disturbance to the surface. There will be no visible signs of tracking after 12 months.

4.4. Access track in “Bad Condition



Figure 3 Photo showing increased surface disturbance and if not repaired could show visible signs of tracking after 12 months.



Figure 4 Photo showing access route in bad condition and if not repaired would still show visible signs of tracking within 12 months.

4.5. Refuelling

- 4.5.1. All vehicles will be re-fuelled by trained staff, will be fitted with a fuel stock bund or other recognised method for containing spills.
- 4.5.2. Transporting of fuel to the work sites may be undertaken by all-terrain vehicles (ATVs). All access routes for the transport of fuel for the excavator machinery must be agreed with the nominated officer and are detailed on the access maps.
- 4.5.3. Alternatively, a suitable bunded fuel cube will be positioned at temporary location(s) on the work site to reduce vehicle movements. The fuel cube will be positioned on site in vicinity of the working area, on level ground away from watercourses and sensitive features. The fuel cube may be repositioned to other working areas on the site periodically and/or removed offsite for refilling offsite. The fuel cube will be removed from site at the end of the works.
- 4.5.4. Re-fuelling of excavators in the field will be kept to a maximum of 85% capacity, using double-bunded containers, drip trays and filter funnels to reduce the incidence of a spill.
- 4.5.5. All re-fuelling will take place away from watercourses and will take place on as level ground as reasonably possible.
- 4.5.6. Emergency spill kits will be carried for all vehicles at all times and use will be in accordance with the manufacturer's instructions.

4.6. General

- 4.6.1. All vehicle access and movements on work sites will be outside of the main ground nesting bird breeding season (1st April – 15th August inclusive).
- 4.6.2. There will be no persistent vehicle tracks visible after 12 months.
- 4.6.3. All vehicle movements on the work site will be kept to a minimum.
- 4.6.4. Operators will be competent in the use of and maintenance of machinery/vehicles, ensuring that vehicle tyre pressure is regularly checked and maintained at the correct pressure and that the vehicle is fit for purpose.
- 4.6.5. All vehicles left on site for the duration of the operations will not be stored on sensitive or recently restored areas. Vehicles will be stored away from well used footpaths or desire lines.
- 4.6.6. All vehicles will follow biosecurity measures to prevent the spread of Avian Flu / other diseases. This will include ensuring vehicles are clean before accessing the work site.

5. Transportation of materials to Work Sites

5.1. Specification for Materials transport

- 5.1.1. The Authority anticipates that transportation of Materials to the Works Sites will mostly require aerial load lifting.
- 5.1.2. Transportation of other Materials may be undertaken by low-ground-pressure tracked ground vehicles as specified in each Works Package. These routes are shown on the Access Maps. The tracking of vehicles will adhere to Section 4 Movement and use of Machinery.
- 5.1.3. The Authority will have the final decision on Work Sites that are suitable for transportation of Materials by tracked Machinery.
- 5.1.4. All other access required to the site will be undertaken on foot, save for vehicle refuelling.
- 5.1.5. The Contractor will mark (with canes/flags) out the Drop Sites for the loads of Materials at the Works Sites.
- 5.1.6. The Contractor will ensure that any means of transporting the Materials is an efficient operation and does not damage the access routes.
- 5.1.7. The Contractor will ensure that it has all the required Equipment and Machinery and personnel to satisfactorily complete the Works.
- 5.1.8. The Contractor must supply all transportation Equipment required for the Works including but not limited to helicopter lifting bags, skips, nets, secondary hooks, extension strops, slings, and Load strops/ropes.
- 5.1.9. The Contractor is responsible for Marshalling and will provide sufficient personnel to Marshal each load and Drop Site at the Works Sites.
- 5.1.10. All airlifting operations will take place outside of bird breeding (31st March to 15th August)
- 5.1.11. Where available lift sites will be located on hard standard using existing reservoir infrastructure / estate tracks.
- 5.1.12. Materials delivered to the lift site will be stored on hardstanding or within 1m of hard standing so as to reduce compaction of surrounding vegetation.
- 5.1.13. Ground staff to direct the material drops will either walk onto site or be dropped off by the helicopter. It is anticipated that two members of ground staff will be needed to direct drops, with another two to act as marshals for the safety of the public.
- 5.1.14. Bags used for lifting will be new to minimise the risk of loss of integrity.
- 5.1.15. Materials will be dropped at works sites shortly prior to materials being needed, and waste bags removed within two weeks, to minimise the loss of light to vegetation

beneath the dropped bags. If there is bad weather or force majeure and waste materials can not be safely removed then a Nominated Officer will contact the Natural England site representative immediately. Mitigation will be discussed on the particular case and a plan for removal put together.

- 5.1.16. Emptied bags will be bundled together (see brash spreading section in enclosed works specification document) to prevent any being blown away.
- 5.1.17. Refuelling of the helicopter will take place by trained staff on hardstanding, away from water courses and sensitive habitats using bunded fuel bowsers.
- 5.1.18. Spill kits will be available at the lift site.
- 5.1.19. Marshalls and warning notices will be in place to protect members of the public.
- 5.1.20. It will be demonstrated that all machinery used is in good working order.
- 5.1.21. All airlifting operations will be compliant with CAA regulations.

6. Temporary Trackway

- 6.1.1. The Trackway will either be made of Aluminium or Heavy Duty Plastic. Specialist contractors will install the Trackway. This will be done in accordance with their individual operational and H&S procedures. The installation vehicle will not leave the existing track. Normal procedure is for trackway panels to be brought on a flatbed lorry with a built in crane and for the trackway panels to be craned into position. The lorry only operates from hard surface or on its own trackway panels.
- 6.1.2. Trackway panels will be installed up to 1 week prior to the materials being delivered. Trackway panels will be removed within one week of “off hiring” them. “Off-hiring” will be initiated once the last materials are removed from the lift site. The trackway panels will be installed in a single day and it will take a single day to remove them after the operation is complete.

7. Bare Peat Stabilisation and Revegetation – Heather Brash

Brash spreading will take place on areas of bare peat within the site boundary, subject to ground-truthing. It is anticipated that these areas will mostly be on gully sides, peat pans or in small isolated patches.

Revegetation of bare peat on the sites begins with the application of chopped heather brash to areas of bare (i.e. lacking vegetation cover) peat. This helps stabilise the peat and creates a microclimate suitable for growing the nurse crop in (see below).

7.1. Environmental Mitigations

- 7.1.1. Dumpy bags of 1 m³ of brash will be airlifted to drop locations on the works site.
- 7.1.2. The brash may be harvested from another site, in which case it will have cleared biosecurity checks focused on pests and disease such as heather beetle and Phytophthora as per the MFFP “Brash passport” protocol.

- 7.1.3. Brash will be spread over areas of bare peat according to the specification.
- 7.1.4. Brash will be emptied on to areas of bare peat and spread to a thickness of about 1 cm by rake or other hand tool.
- 7.1.5. Spreading will be undertaken by small teams of people (5-10) on foot.
- 7.1.6. Empty bags will be grouped together and securely fastened ready for removal from the site.
- 7.1.7. Exact timings and duration of the work will be subject to brash availability and weather conditions during the works delivery period.
- 7.1.8. Brash spreading locations will be recorded on GPS units.

7.2. Supply of Heather Brash

- 7.2.1. Heather brash will be harvested with a low seed burden when possible. Ideally the cutting will take place in August and September, prior to development/maturing of seed. Alternatively brash will be harvested between December and March, when seed burden is low
- 7.2.2. Please refer to Section 10 for heather cutting methodology.
- 7.2.3. The Heather Brash will be double chopped consisting of a fragment size of approximately 150-200 mm;
- 7.2.4. The Heather Brash will be supplied in new open top dumpy Bags.
- 7.2.5. Each Bag will be filled to full capacity.
- 7.2.6. If Bags are deemed by the Nominated Officer (in its absolute opinion) not to be full they will be rejected or doubled up with other part empty Bags to be counted as a single Bag. The decision of the Nominated Officer shall be final.
- 7.2.7. Each Bag must only contain Heather Brash.
- 7.2.8. Bags containing a proportion of foreign materials (e.g. soil, grass or other plant materials other than heather) as deemed inappropriate by the Nominated Officer shall be rejected. The decision of the Nominated Officer shall be final.
- 7.2.9. The Heather Brash must be produced to a suitable standard to withstand:-potential multiple handling during the Delivery process to the Delivery Site and Lift Site; preparation of Heather Brash for Aerial Works; and transport of the Heather Brash to final point of use as underslung load beneath a helicopter; any other process reasonably associated with the use of Heather Brash.

7.3. Delivery of the heather brash

- 7.3.1. The Contractor will deliver the Bags of Heather Brash to the Authority's Delivery site / Lift site.

7.3.2. The Contractor will ensure that the Bags of Heather Brash are placed upright upon delivery, so they are ready to be prepared for aerial load lifting. The bags of Heather Brash should not be double stacked.

7.3.3. The Contractor will deliver the Bags of Heather Brash to the Delivery Site / Lift Site in the manner agreed with the Nominated Officer.

7.3.4. The Bags of Heather Brash should be placed in piles of no more than 100 Bags and a clear gap should be left between the piles of Bags to enable the Nominated Officer to easily count the delivered Bags.

7.4. Marshalling of the individual bag drops

7.4.1. The Works Sites contain areas of bare peat which will require accurate spreading of the Heather Brash to maximise the efficiency of the Works as a whole.

7.4.2. The Authority will provide maps and GIS shape files of the bare peat areas to the Contractor in GPX format. These must be loaded onto a GPS unit and used by the contractor to locate the bare peat areas at the Works Site. The Authority will supply no physical markers on the ground to identify the Bare Peat Areas.

7.4.3. The Contractor will be responsible for marshalling of the individual bag drop locations during the airlifting of the Heather Brash to the Works Site.

7.4.4. The Contractor will be responsible for ensuring accurate placement of the individual bag drops of Heather Brash on bare peat areas at the Works Site.

7.4.5. If the Contract specifies the **number** of Bags that must be spread, then, provided the Specification has been followed, the Contractor will not be obliged to cover a specific area. Any additional Bags required to cover a specific area will be agreed between the Nominated Officer and the Contractor and treated as a Contract Variation. If un-spread bags (including wholly or partially un-spread Bags) of Heather Brash remain on any of the bare peat areas after the bare peat has been fully covered with spread Heather brash in accordance with the Specification, the Contractor will airlift the un-spread bags to a new spreading location agreed by the Nominated Officer and spread the bags in accordance with the Specification. Such relocation of Bags shall not be treated as a Contract Variation.

7.4.6. If the Contract specifies that the Contractor must cover a specified **area** with Brash, without determining the **number** of bags, then the Contractor, must supply as many Bags as is necessary to fulfil the Contract requirement. If un-spread bags (including wholly or partially un-spread Bags) of Heather Brash remain on any of the bare peat areas after the bare peat has been fully covered with spread Heather brash in accordance with the Specification, the Contractor will airlift the un-spread bags to a new spreading location agreed by the Nominated Officer and spread the bags in accordance with the Specification. Such relocation of Bags shall not be treated as a Contract Variation.

7.4.7. If the Contract specifies that the Contractor is responsible for determining the number of Bags of heather brash required to cover a specified area in accordance with the Specification, and if after the Contractor has airlifted and spread the Heather Brash, gaps in the coverage of the bare peat remain in the context of the Specification (in the Nominated Officer's opinion), the Contractor must supply and airlift additional Bags to the Works Site and spread these Bags to ensure the bare peat is fully covered in accordance with the Specification. Such relocation of Bags shall not be treated as a Contract Variation.

7.5. Spreading of material

- 7.5.1. The Works Sites contain small patches of bare peat amongst vegetated areas which will require accurate spreading of the Brash to maximise the efficiency of the Works as a whole.
- 7.5.2. The Contractor will be provided with the Works shapes in GPX format. These shapes must be loaded onto a GPS and used on site to locate bags of brash and spreading areas.
- 7.5.3. All Bare Peat within the Works shapes must be covered with Heather Brash.
- 7.5.4. On flat or undulating bare peat one full Bag of Heather Brash will contain enough Material to cover 49 square metres. This figure is for information purposes only and must not be relied upon.
- 7.5.5. On gully sides (including reprofiled) one full Bag of Heather Brash will contain enough Material to cover 25 square metres. This figure is for information purposes only and must not be relied upon.
- 7.5.6. The Material shall be delivered to the Works Site in open top Bags.
- 7.5.7. If the lifting loops of the Bags have been tied together with baler twine, the twine MUST be collected along with all other Waste Materials including ropes.
- 7.5.8. In some instances the Contractor will be expected to move Material to the required bare peat area within the Works Site.
- 7.5.9. The Contractor is required to spread the Material over the areas of bare peat at the Works Site in the manner demonstrated to it by the Nominated Officer at the Works Commencement Date (without any variation save with the prior consent of the Nominated Officer).
- 7.5.10. Material is to be spread evenly with no clumps or lumps to the satisfaction of the Nominated Officer.
- 7.5.11. Material is to be spread thinly enough to allow seed to fall through and make contact with the soil.
- 7.5.12. In the event that there is not enough Bare Peat area on the Works Site on which to spread a Bag/the Bags then the Contractor must leave any remaining Material in Bags

and GPS the location of the remaining Bag/s. The Contractor must then supply the GPS location to the Nominated Officer who will then provide another suitable spreading location for the Bag/s to be moved to and spread.

7.5.13. In the event that there is not enough Material to cover the bare peat area in the Works Site where the Bags have been dropped then the Contractor must spread the Material to the required standard over as much of the bare peat area as is practicable and then place a marker flag in the centre of the remaining area of bare peat and GPS the location of the flag. The Contractor must then move more Material to the location.

7.5.14. The Contractor must ensure that the Material is spread as soon as possible after it has been delivered to the Drop Site.

7.6. Preparing Bags for removal by airlifting as underslung load

7.6.1. The Contractor is responsible for preparing empty Bags and Waste Materials for removal from the Works Site (and for supplying the rope required to do so) and for removing them in accordance with this Contract and as soon as possible after spreading of the Material has been completed.

7.6.2. The Methodology detailed in this Section is designed to prevent the risk of empty Bags being blown around the Works Site. It is also designed to reduce the risk of loose Bags becoming entangled with the Helicopter during transportation from the relevant Works Site.

7.6.3. One empty Bag (“the container bag”) is to be filled with between 10 and 20 other empty Bags.

7.6.4. The Contractor should ensure that the top of the container bag can be tied together in order that the contents of the container bag are not spilled.

7.6.5. Each container bag is to be sealed by knotting two of the diagonally opposite haul tabs together to create a bow. The remaining two free haul tabs should then be pulled through the loops of the bow created by the knot. The photograph below illustrates how the haul loops should be knotted.



7.6.6. The container bags must be grouped together in batches and tied to each other (as illustrated on the photograph below).



7.6.7. Contractors must maximise (so far as reasonably able) the number of container bags in any one batch to improve the efficiency of bag removal by airlifting.

7.6.8. The batches of container bags must not be placed in stream channels or other watercourses.

7.6.9. The location and number of batches of container bags are to be recorded and grid references or GPX files supplied to the Nominated Officer.

8. Application of Lime, Seed and Fertiliser

8.1. Environmental Mitigations

Lime, seed and fertiliser (LSF) will be applied to bare peat areas that have been covered with heather brash as the next stage of bare peat revegetation. The purpose of this stage is to establish a crop of amenity grasses that meshes with the heather brash to form a 'scab' over the bare peat. This in turn stabilises the peat and creates conditions that will allow native bog species to recolonise the area through reintroduction and natural processes.

One or more of the three components of this application can be applied by hand and/or aurally from a helicopter. The most suitable method will be selected based upon logistics and achieving the best outcome. The application method will be detailed in the Works Plan for each site.

1. Seed will comprise a mixture of:
 - amenity grasses applied at 49 kg per ha if applied aurally*;
 - *Deschampsia flexuosa* applied at 1 kg per ha if applied aurally*;

*These quantities are doubled if application is by hand.
2. Granulated lime will be spread at a rate of up to 1000 kg per ha, and NPK fertiliser at a rate of up to 220 kg per ha for the initial treatment, and 160 kg per hectare for maintenance treatments.
3. Materials will not be stored on site.
4. Application will not occur during heavy rain to minimise the risk of leaching and run-off.

Terrestrial Application		Total Amount in kg				
No. Square Metres	Description	Lime	Seed	Fertiliser	Maintenance lime	Maintenance Fertiliser
10000	1 hectare	1000	100	220	1000	160
49	Bag of brash on bare peat	4.9	0.5	1.1	4.9	0.8
25	Bag of brash on reprofiled slope	2.5	0.3	0.6	2.5	0.4

Aerial Application		Amount in kg				
No. Square Metres	Description	Lime	Seed	Fertiliser	Maintenance lime	Maintenance Fertiliser
10000	1 hectare	1000	50	220	1000	160
49	Bag of brash on bare peat	4.9	0.3	1.1	4.9	0.8
25	Bag of brash on reprofiled slope	2.5	0.2	0.6	2.5	0.4

For aerial application

1. Aerial application will not occur between 31st March and 15th August of each year.

2. Lime and fertiliser will be transported in waterproof, sealed plastic double-lined bags.
3. Bags will be lifted and emptied into a hopper unit to act as a working store at an off-site lift site.
4. The application hopper will be filled from this working store using a loader while the helicopter hovers.
5. The helicopter will fly to the application area at an approximate height of 50 m and apply the material from a height of 25 m.
6. A GPS-based navigation system will be used to ensure the correct areas are treated and to record the treatment.
7. To ensure accuracy of application, aerial application will not take place on windy days.

For terrestrial application

1. Materials will be transported out to the work areas using a low ground pressure vehicle (less than 3psi) or carried out on foot.
2. Lime and fertiliser will be contained within double-lined waterproof bags.
3. Materials will be spread by hand by staff on foot.

8.2. Materials

8.2.1. The Supply of lime and fertiliser will be organised by the Authority. The Contractor will need to co-ordinate delivery of lime and fertiliser to the Delivery / Lift Site.

8.2.2. Granulated lime fertiliser – ‘Lime’

8.2.2.1. The application rate for initial and maintenance applications is 1000 kg per ha for all Works Sites.

8.2.3. N:P:K fertiliser – ‘Fertiliser’

8.2.3.1. The application rates are required to achieve an application ratio of:

8.2.3.1.1. 40 kg N: 120 kg P₂O₅: 60kg K₂O per ha for initial lime and fertiliser application.

8.2.3.1.2. 40 kg N: 60 kg P₂O₅: 60 kg K₂O per ha for maintenance lime and fertiliser application

8.2.4. Nurse crop grass seed mix – ‘Seed’

8.2.4.1. The nurse crop seed mixture is a blend of the following species:

- Perennial rye-grass (*Lolium perenne*) – 3 varieties.
- Fine-leaved sheep’s fescue (*Festuca longifolia*)
- Sheep’s fescue (*Festuca ovina*)
- Highland bent – (*Agrostis castellana*)
- Wavy-hair grass (*Deschampsia flexuosa*).

- Seed must be applied at a rate of 50kg per hectare **if applied aerially**, or 100kg per hectare **if applied by hand**.

8.3. Storage and delivery of Materials

- 8.3.1. All Materials will be stored by the Contractor at the Contractor's cost following receipt by the Contractor pursuant to a Purchase Order, until application of the Materials on the Works Sites, as required.
- 8.3.2. The Contractor is responsible for sourcing and/or subcontracting the use of Storage Sites to hold the Materials prior to Delivery to Lift/Works Sites.
- 8.3.3. The Contractor must ensure as a minimum standard that any Storage Site is secure and wind and watertight and ensures that all Materials remain fit for purpose at all times until the Works Commencement Date and for carrying out and completing the Works.
- 8.3.4. The Contractor must satisfy itself that the vehicle chosen for the forwarding of Material from the Storage Site can reach the Lift/Works Sites.
- 8.3.5. The Contractor shall arrange for the appropriate quantities of Material to be forwarded to the Lift/Delivery Sites in preparation for application.

8.4. Methodology

- 8.4.1. It is the responsibility of the Contractor to ensure it can supply all Equipment required to complete the Works. The Contractor must be capable of transporting this Equipment to the Lift/Works Sites.
- 8.4.2. At each Works Site the work schedule should follow the same basic timeline, specifically:
- 8.4.3. The Lime must be applied at a rate of 1000 kg per hectare.
- 8.4.4. The NPK Fertiliser be applied after the application of Lime, and about two weeks after the application of Seed.
- 8.4.5. Seed application follows at a rate of 50kg per hectare **if applied aerially**, or 100kg per hectare **if applied by hand**.
- 8.4.6. Any deviations from this work schedule must be agreed with the Nominated Officer.

9. Gully Blocking

9.1. General Environmental Mitigations for gully blocking

- 9.1.1. Evidence of protected animal species within gullies was looked for and not found as part of surveying work.
- 9.1.2. Construction will start as close to the top of the channel as reasonably practicable and continue downslope.

9.1.3. Waste Materials will be grouped together and securely fastened ready for removal from the site.

9.1.4. Excess Materials and Waste Materials will be removed from Work Sites and Lift Sites within 1 week of completion of constructing the last Dam.

9.2. Construction of dams at the Works Sites

9.2.1. Construction specifications for all Dam types are detailed in this section.

9.2.2. The locations of the Works Sites are anticipated to be several kilometres from the nearest metalled road or surfaced vehicle track.

9.2.3. Quantities of Dam units and locations of gully systems to be blocked at the Works Sites will be provided to the contractor in the Works Package..

9.2.4. The Contractor will construct Dams at the Works Sites in accordance with the Works Package and the construction specifications detailed in this section, unless specified in the Tender Package.

9.2.5. There may be some areas within the Works Site that will be left free from any type of Works (“the Exclusion Areas”). These will be identified to the Contractor by the Nominated Officer on or before the Works Commencement Date. The Contractor must not and must ensure that subcontractors must not carry out any Works in the Restricted Areas.

10. Gully Blocking - Timber Dams

10.1. Environmental Mitigations

- 10.1.1. Timber will be airlifted onto the works site in packs, containing up to 80 planks.
- 10.1.2. The material is driven into the peat using hand tools ensuring at least half its height is within the peat enabling the material to withstand the volume and pressure exerted by the water which will build up behind it.
- 10.1.3. The dam will be driven into the sides of the gully far enough for structural strength and to prevent scouring around the sides.
- 10.1.4. One or more panels in the centre of the dam will be driven slightly further into the peat to create a wide, low point allowing water to overflow in the middle of the dam, to prevent side cutting.
- 10.1.5. Dams will be constructed so as to minimise the risk of water overflow resulting in erosion.
- 10.1.6. Care will be taken to ensure that the dams are installed at an appropriate height (i.e. lower than the surrounding vegetation) to reduce their visual impact.

10.2. Supply of Timber

- 10.2.1. Each Timber Dam is to consist of between 4 & 6 fencing boards and 2 stakes.
- 10.2.2. Fencing Boards should be: untreated FSC timber; either softwood or hardwood or equivalent and approved by the Nominated Officer; - 2400 mm X 125 mm X 25 mm.
- 10.2.3. Stakes should be untreated FSC timber; either softwood or hardwood or equivalent and approved by the Nominated Officer – 1500 mm x 75 mm x 75 mm.

10.3. Construction of Timber Dams

- 10.3.1. Ditch vegetation will be scraped back along the line of the Timber Dam and put to one side before putting in the stakes, and then moved back into place on Timber Dam completion.
- 10.3.2. The stakes will then be driven into the base of the gully at approximately 1000 mm centres.
- 10.3.3. The first fencing board will be completely buried in the peat to prevent scouring at the base of the Timber Dam.
- 10.3.4. The fencing boards will be keyed into the Gully sides by at least 20 cm on both sides of the Gully, to prevent erosion at the Gully edges.
- 10.3.5. Fencing boards will be nail-fastened using appropriate nails (on the upstream side), to the supporting upright fencing stakes.
- 10.3.6. The top board of each Timber Dam will have a right angled, 50 mm deep x 200 mm long square shaped notch cut in it to its central point, to allow water to flow through the middle of the Timber Dam rather than scour the sides of the gully.

- 10.3.7. Timber Dams will require a splash plate placing on the Gully floor immediately downstream of the square notch in the Timber Dam, to prevent turbulence erosion as water flows over the top. Splash plates are to be implemented using locally won stone or other material with the Nominated Officer's prior approval.
- 10.3.8. Timber Dams will be placed at approximately 8 metre intervals, with Timber Dams closer together on steeper slopes and further apart on flatter areas, following the "Top to Toe" principal i.e. the top of the downstream Dam should be level with or higher than the bottom of the upstream Dam.
- 10.3.9. Variation in the positioning of the Timber Dams may be required in order to take advantage of the natural topography.
- 10.3.10. Timber Dams will be constructed up to a typical maximum of 3m in width. Timber dams may be constructed in steeper gullies than peat dams, however the suitability of the peat and feasible spacing of preceding & subsequent dams will determine the maximum slope as opposed to a specified maximum angle alone.

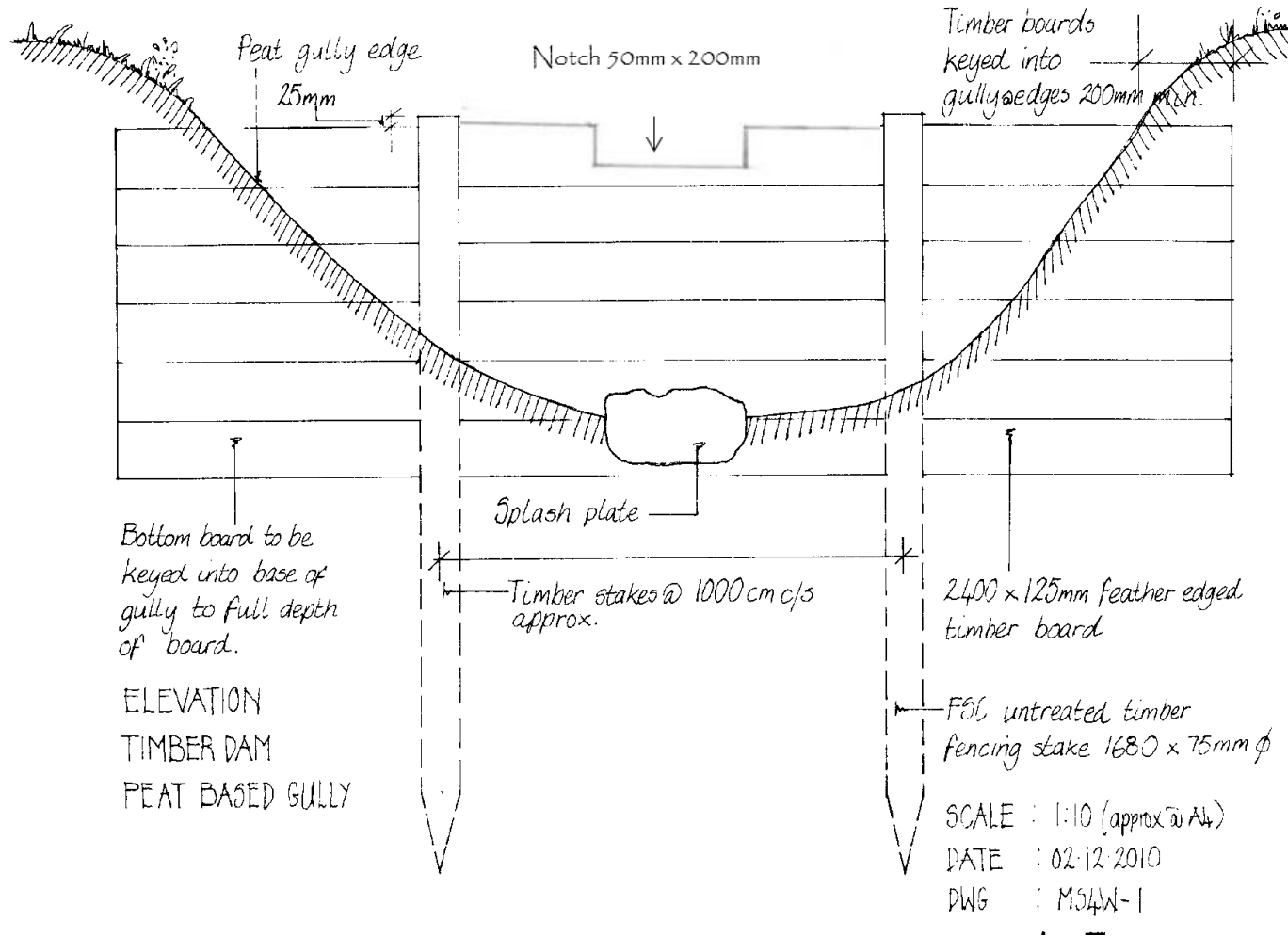
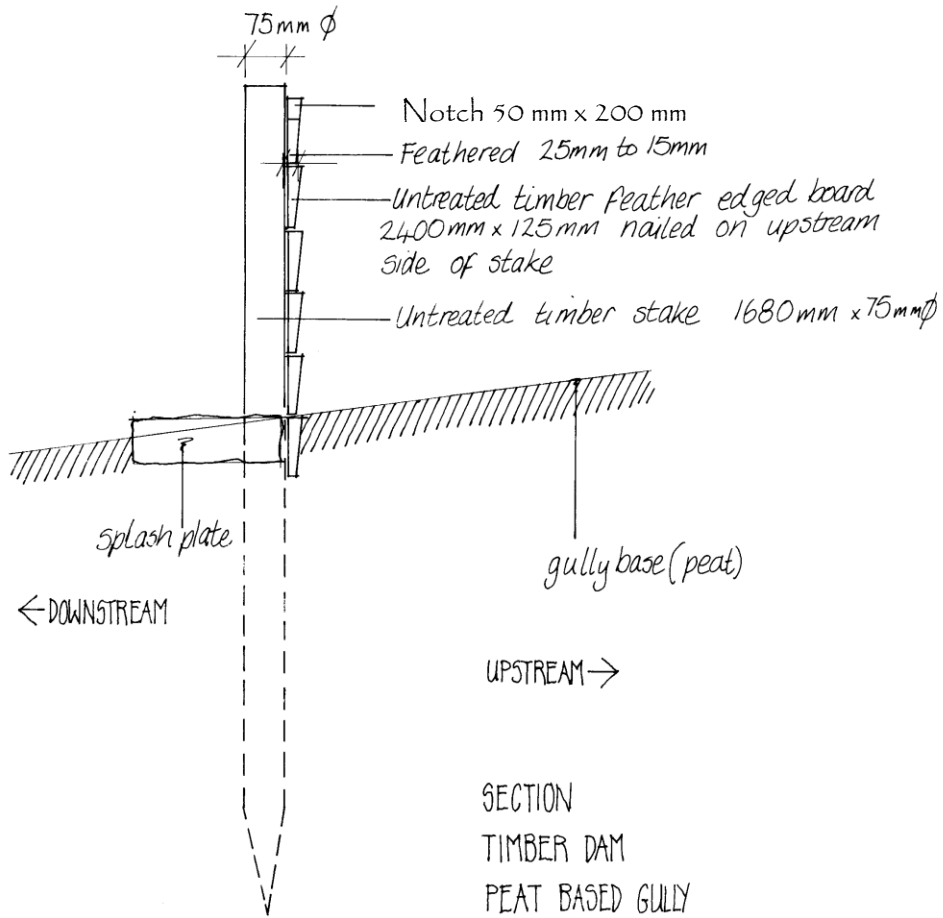

Figure 5



SCALE : Approx 1:10 (@ A4)

DATE 03.12.2010 AMENDED 04.01.2011

DWG : MSLW-2a

Figure 6

11. Gully Blocking - Leaky Timber Dams

Mitigation and supply as per Gully Blocking – Timber Dams

11.1. Construction of Leaky Timber Dams

- 11.1.1. Ditch vegetation will be scraped back along the line of the Timber Dam and put to one side before putting in the stakes, and then moved back into place on Timber Dam completion.
- 11.1.2. The stakes will then be driven into the base of the gully at approximately 1000 mm centres.
- 11.1.3. The first Timber Plank will be completely buried in the peat to prevent scouring at the base of the Timber Dam.
- 11.1.4. The Timber Planks are to be keyed into the gully sides by at least 20 cm on both sides of the gully, to prevent erosion at the gully edges.
- 11.1.5. Timber Planks will be nail-fastened using appropriate nails (on the upstream side), to the supporting upright fencing stakes.
- 11.1.6. A gap of 10mm will be left between planks above the first three constructed planks, to allow water to percolate through the Dam during periods of high flow. The gaps near the edges of the Dams will need to be covered up with off-cut timber planks to prevent erosion at the gully edges.
- 11.1.7. The top plank of each Timber Dam will have a right angled, 50 mm deep x 200 mm long square shaped notch cut in it to its central point, to allow water to flow through the middle of the Timber Dam rather than scour the sides of the gully.
- 11.1.8. Timber Dams will require a splash plate placing on the gully floor immediately downstream of the square notch in the Timber Dam, to prevent turbulence erosion as water flows over the top. Splash plates are to be implemented using off cuts of Timber Planks or locally found stone or other material with the Nominated Officer's prior approval.
- 11.1.9. Timber Dams will be placed at approximately 8 metre intervals, with Timber Dams closer together on steeper slopes and further apart on flatter areas, following the "Top to Toe" principal i.e. the top of the downstream Dam should be level with or higher than the bottom of the upstream Dam.
- 11.1.10. Variation in the positioning of the Timber Dams may be required in order to take advantage of the natural topography.

Leaky Timber Dam Construction

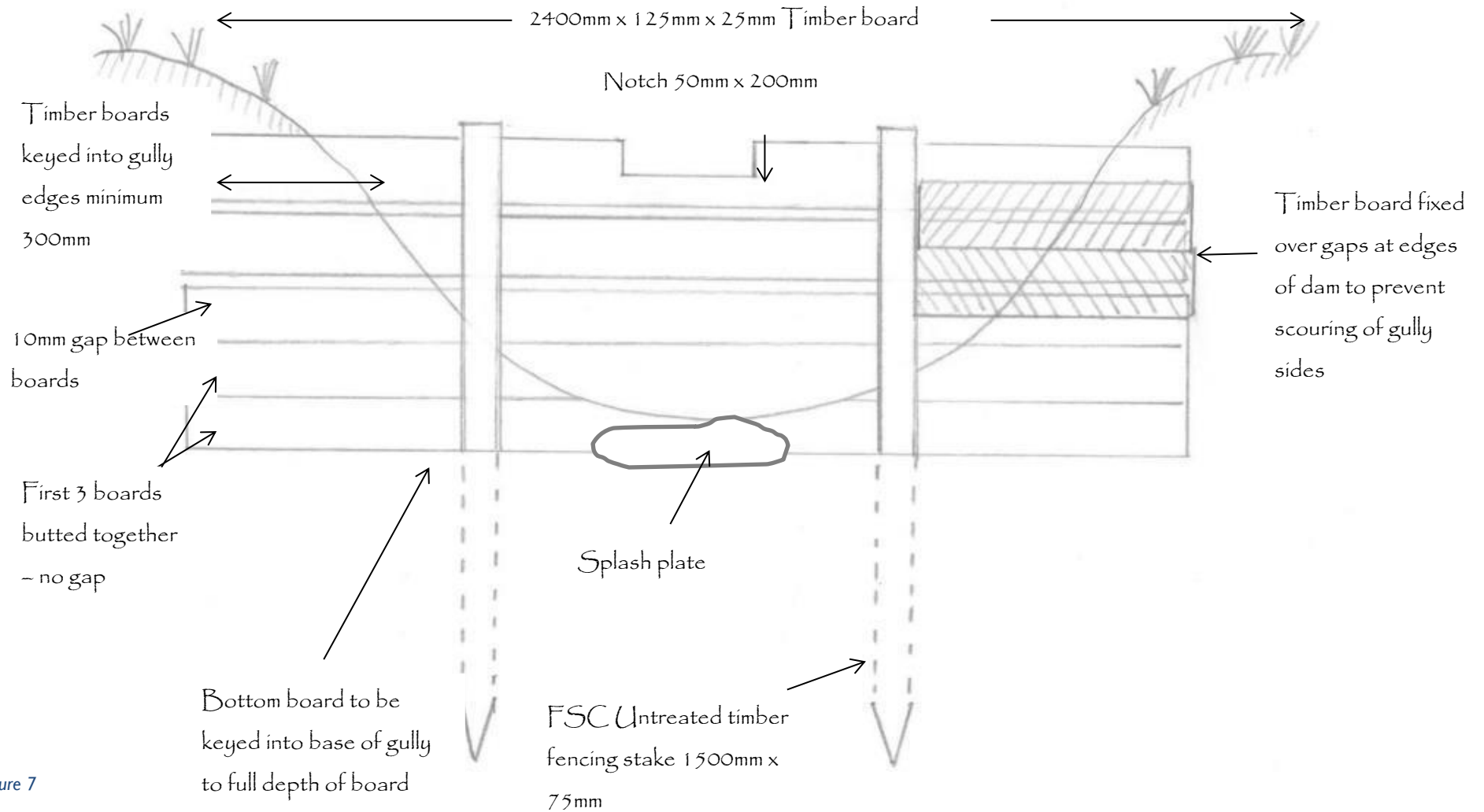

Figure 7

Cross Section

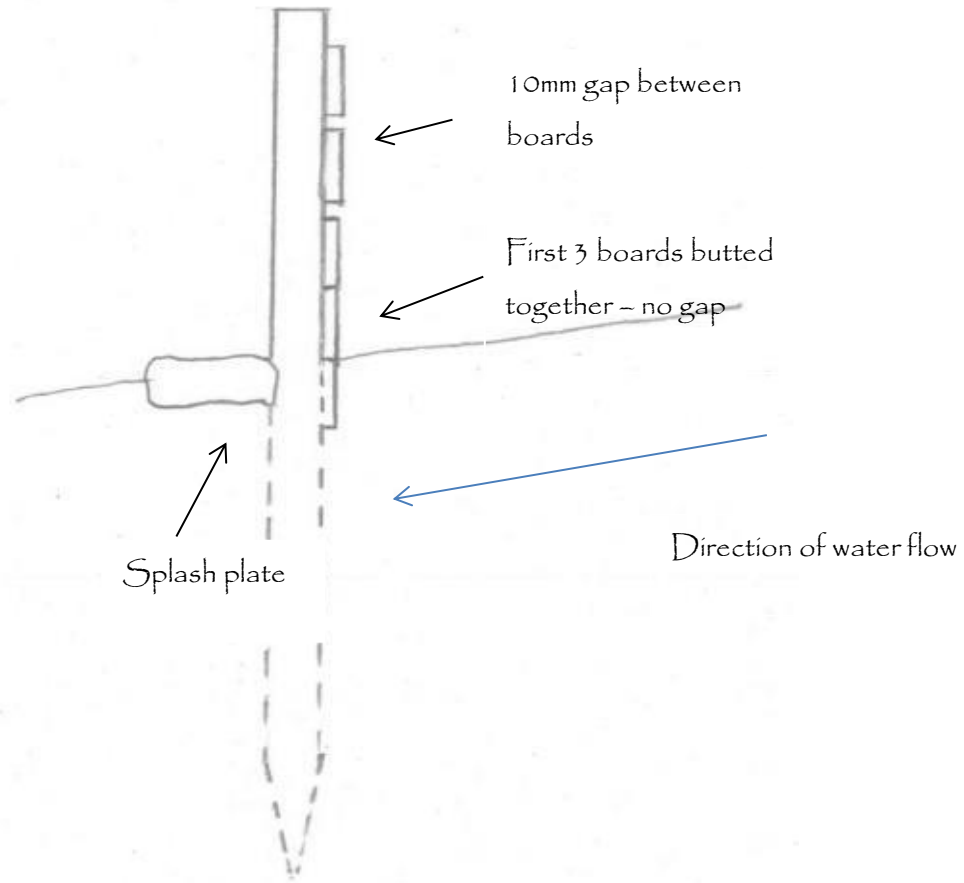

Figure 5

12. Gully Blocking – Stone Dams

12.1. Environmental Mitigations

- 12.1.1. Stone will be delivered to the helicopter Lift Site
- 12.1.2. A telehandler or excavator will load the stone into skips provided by the aerial works contractor. Each skip and load should contain 750kg of stone. The Authority anticipates that this will require the Contractor to provide a telehandler or excavator to load gully blocking stone into skips provided by the Authority's aerial works contractor
- 12.1.3. Stone will be airlifted by helicopter in a load containing 750 kg per dam.
- 12.1.4. The load of stone will be positioned directly in place in the gully at the identified GPS location
- 12.1.5. Once the helicopter has placed the stone, a small team of staff will manually move the stones by hand into a dam shape.
- 12.1.6. Where there is little sediment input into the gully further upstream, the stone dam may be turfed using existing vegetation. This will help to make the stone dam less porous and create better conditions for Sphagnum mosses to colonise.
- 12.1.7. Turfing of stone dams will use hand tools.
- 12.1.8. Turves will be taken from the existing vegetation in the bottom of the gully and placed over the face of the stone dam. The places where turf has been borrowed from will be landscaped and remaining vegetation stretched over the surface to repair the area.

12.2. Supply of Stone

- 12.2.1. Clean millstone grit;
- 12.2.2. Not less than 150 mm in any dimension and not greater than 250 mm in any dimension;

12.3. Construction of Stone Dams

- 12.3.1. Unless advised otherwise by the Nominated Officer on the Works Site, each Stone Dam will contain a single Dam Unit and therefore each helicopter load is to weigh approximately 750 kg.
- 12.3.2. Dependent on the size and nature of the Gully more than one Dam Unit may be required to complete the Stone Dam.
- 12.3.3. Stone Dams will be a minimum of 50 cm high and at least 75 cm in transverse width upstream to downstream and span the full width of the Gully.

- 12.3.4. Stone Dams must be no taller than 1 m in height for safety reasons.
- 12.3.5. Stone Dams should have a steep face (approximately 60 degrees) on the upstream side and have a slope of approximately 45 degrees on the downstream face.
- 12.3.6. Stone Dams should be higher at each side than in the middle to allow water to flow down the middle of the downstream face of the dam and prevent scouring around the sides of the Dam.
- 12.3.7. There will be some hand movement of Stone required by the Contractor after the Dam Unit has been initially dropped into place to ensure that the Stone Dam conforms to the right shape and size as set out above.
- 12.3.8. Stone Dams, consisting of more than a single Dam Unit, may be placed at pinch points, confluences, at locations to co-ordinate with other works (i.e. as baffles to co-ordinate with gully side reprofiling), or changes from mineral to peat based substrate.

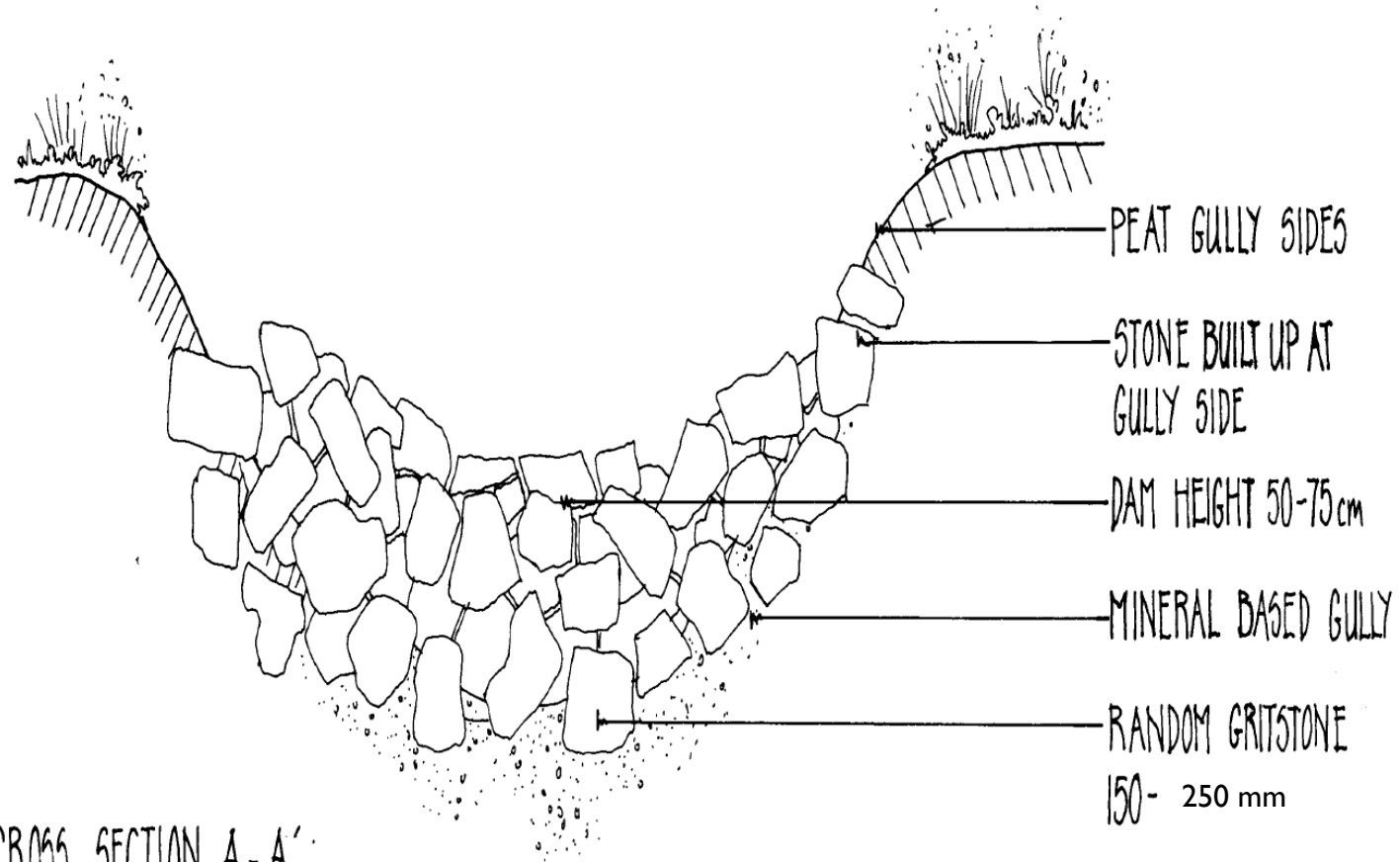

CROSS SECTION A-A':
STONE DAMS

Figure 9

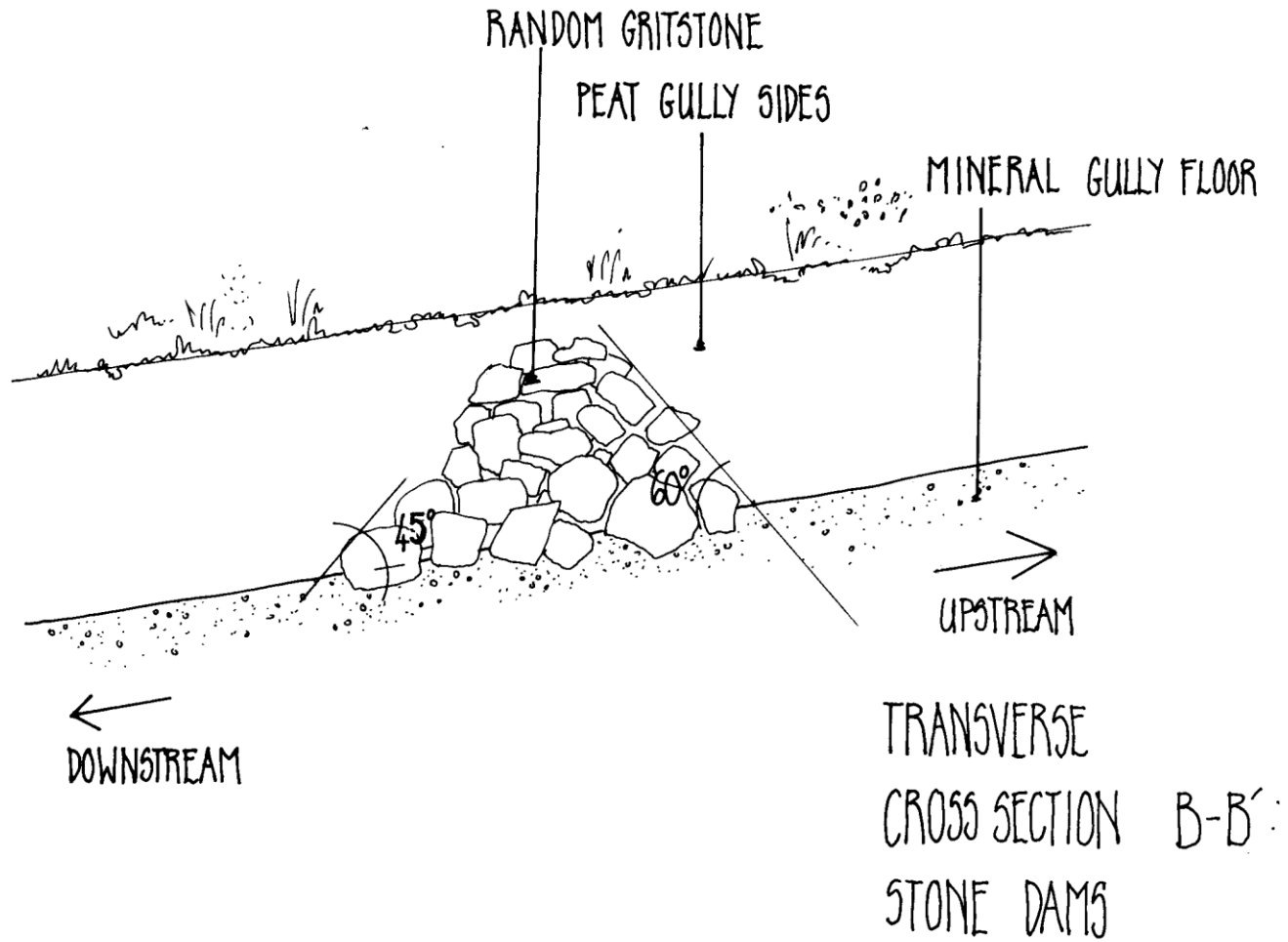
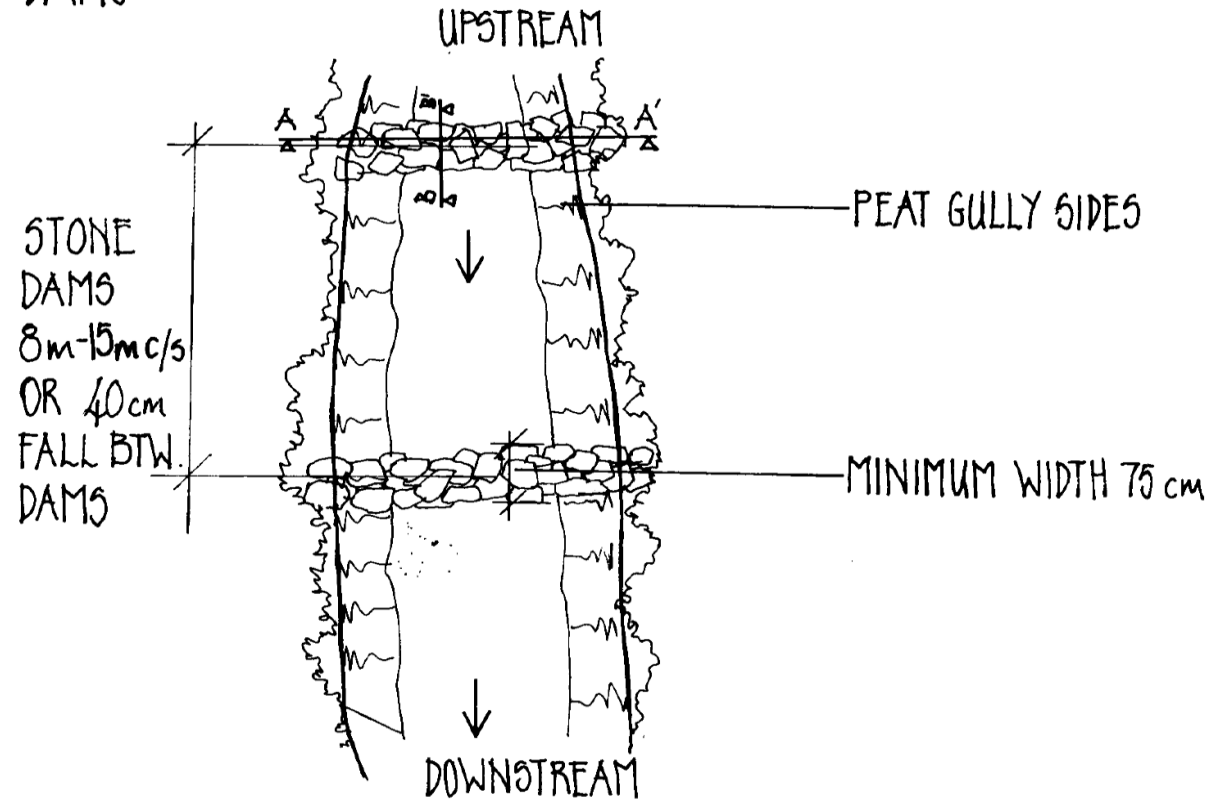

Figure 10

CROSS SECTION A-A':
STONE DAMS



PLAN: STONE DAMS

Figure 11

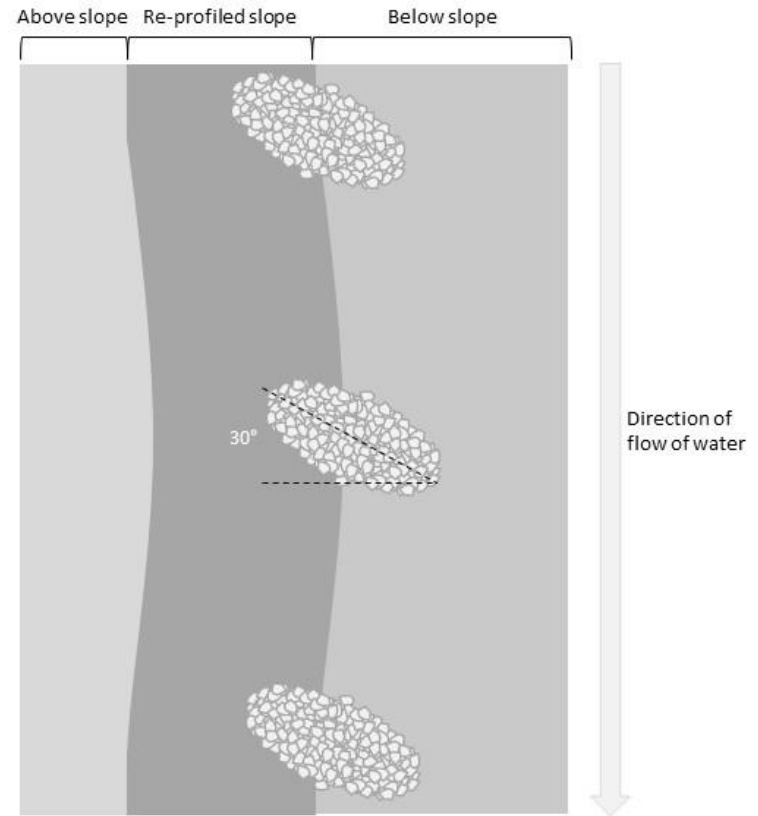
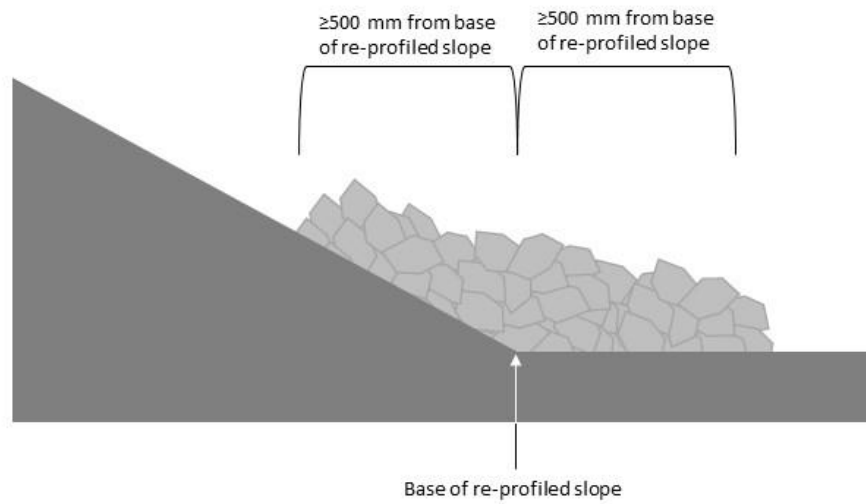

Figure 12. Stone baffle construction specification

13. Peat Dams

Peat dams will be installed in small to moderately sized erosion gullies leading from the peat pans and small gullies into which heather bales or coir logs will be installed and into the biggest erosion gullies. Their immediate purpose is to hold water and locally raise the water table to the benefit of vegetation, invertebrates and the birds that feed on them. In the longer term, the pools created can be colonised by *Sphagnum* mosses leading to eventual terrestriation of the pool. They are constructed from waterlogged (impermeable) peat dug from within and around the erosion channel by machine and are situated in way that creates chains of pools along the gully length.

13.1. Environmental Mitigations

- 13.1.1. Peat dams will be constructed in peat-based channels no wider than 4m in width.
- 13.1.2. Well-humified, 'putty-like' peat will be used to construct the dam wall.
- 13.1.3. Peat dams will be constructed where there is sufficient depth of peat (>75cm) within the channel to ensure a good seal at the base of the dam; and
- 13.1.4. Peat dams will be constructed where there is sufficient vegetation to supply turves.
- 13.1.5. Peat dams will be constructed so as to minimise the risk of water overflow resulting in erosion.
- 13.1.6. Machines will remain on site until the peat dam and re-profiling work has finished, after which they will be tracked off via the same access point.
- 13.1.7. Once machines are in place, operators will walk on and off the works site each day.

13.2. Borrow Pits

- 13.2.1. Work will only use borrow pits where peat in a gully location is shallow, disturbed or degraded and therefore not suitable for making dams.
- 13.2.2. The location and use of borrow pits will follow an assessment of the integrity/stability of the peat mass, and will be:
 - 13.2.2.1. Within range of the excavator arm
 - 13.2.2.2. Limited in size and depth to supply peat for a maximum of two peat dams
 - 13.2.2.3. Peat will only be sourced where there is sufficient depth of peat to prevent exposure of the underlying mineral ground.
- 13.2.3. Borrow pits will be located within 5m of the dam location where there is more than 1m of peat depth and away from pristine blanket bog or sensitive features such as flushes. Peat will not be extracted down to the mineral layer.
- 13.2.4. The design will minimise the impact by siting borrow pits away from high quality habitats so that the integrity of undisturbed parts of the peat mass is not compromised.

- 13.2.5. Avoiding important sensitive habitat features such as Sphagnum hummocks and bog pools
- 13.2.6. When removing the turves of a donor site, the root zone will be left intact, and the turves laid to one side.
- 13.2.7. Before moving on, the sides of the donor site will be re-profiled using these reserved turves so as to create a vegetated shallow depression that will be no deeper than pools created by adjacent grip/gully blocking and will not exceed 1m depth.
- 13.2.8. A completed borrow pit will be a vegetated round depression in the ground where water is likely to collect. Dimensions of borrow pits will be no larger than 2m in diameter and no deeper than 1m (see Figures 14 and 15 for examples).
- 13.2.9. The siting of borrow pits will be suitably spaced so as to not form a string of excavations. Where dams are closer together, the borrow pits will be sited on alternate sides of the gully to reduce any possible connectivity between existing erosion features, and areas with developing erosion features.
- 13.2.10. The locations of borrow pits will be recorded using GPS so that their recovery can be monitored.

13.3. Archaeological Mitigations

In order to reduce the risk of damage to potential archaeological artefacts at the peat/mineral interface or within the lower peat deposits “basal peats”. The exact specification will be confirmed, but will likely comprise the following methodology

13.3.1. The methodology used for peat dam construction will depend on the surveyed peat thickness (within the gully/grip) in the vicinity of the proposed peat dam location:

13.3.1.1. No peat dams shall be constructed where surveyed peat thickness is <1 m.

13.3.1.2. Where peat thickness is between 1 m and 1.5 m; excavation for peat dam construction shall be limited to a maximum 0.5 m depth below base of gully/grip. Additional peat/turves for peat dam construction must be obtained from borrow pits outside of the gully/grip.

13.3.1.3. Where peat thickness at peat dam locations is greater than 1.5 m thickness, the construction methods should avoid excavating within the bottom 0.75 m of peat deposits and should only excavate to the depth required for successful peat dam construction. Additional peat or turves for peat dam construction should be taken from borrow pits outside of the gullies where practicable.

13.4. Peat dams in larger gullies

Low peat dams are a specific variation from standard peat dams, they are located and prescribed as follows:

13.4.1. In gully systems:

13.4.1.1. Where channel flow is higher than required for habitat recovery. The Feature of the SSSI, blanket bog, is being actively degraded or drained (not necessarily eroded) by this high flow.

13.4.1.2. Where topography prevents the shedding of water out to ground either side of the gully.

13.4.1.3. Where vegetation reduces the efficacy of stone dams as an alternative technique.

13.4.1.4. To interrupt the flow of surface water in gently sloping, low-energy channels and create shallow pools or waterlogged areas:

13.4.1.5. In peat-based channels not suitable for peat dams (e.g. >4 m wide or with insufficient peat depth):

13.4.1.6. In wide channels and shallow depressions on slopes of 1–5°.

These peat dams are similar in design to standard peat dams, but are generally lower in height and designed to allow excess water to overtop the dam wall. The small pools and waterlogged conditions created behind the dams will develop peat-formation and mire species, particularly Sphagnum. See Figure 13 for an example photograph.

Peat dams in larger gullies will be built according to the Peat Dam principles and the following:

13.4.2. Dams will span the full width of the channel be 'keyed in' at either side of the channel such that scouring around the sides is prevented, and be well-turved to withstand overtopping by excess water.

13.4.3. Dam walls will be twice as deep in cross-section as they are tall, with gently sloping sides.

13.4.4. Hydraulic failure will be mitigated through;

13.4.4.1. increased dam frequency and low dam height.

13.4.4.2. Not building on steeper slopes (>5 degrees)

13.4.4.3. Not building where there is field evidence of high flow periods, e.g. bare peat; active erosion; active or recent deposition of sediment; channel formation; vegetation squashed/pressed/aligned by flowing water.



Figure 13 An example of a peat dam in a larger gully



Figure 14 A borrow pit in the top left corner one year post construction



Figure 15 A borrow pit in the top right 3 months post construction

13.5. Specification for Peat Dams

- 13.5.1. Average Peat Dam spacing will be approximately every 7-8 metres, but will be adjusted according to the angle of the individual grip or gully. See Figure 16.
- 13.5.2. A pre-requisite for Peat Dams is that there is sufficient depth of peat on Site where the gully is situated to provide material to construct the Dam.
- 13.5.3. The peat to be used must be well-humified so that it is sufficiently impermeable. Highly oxidised or loose “sloppy” peat should not be used. Peat must be removed within the near vicinity of the Peat Dam, including from within the relevant ditch/gully itself and where appropriate from borrow pits outside the ditch/gully.
- 13.5.4. The construction of Peat Dams should follow the process below.
- 13.5.5. The excavator strips out the vegetation from the bottom of the gully at the chosen Peat Dam location. The excavator ensures the root zone is left intact in the turves that are removed, and lays the turves to one side for later use.
- 13.5.6. The excavator digs into the sides and base of the gully parallel with the intended line of the Peat Dam wall. The resulting ditches should cut at least 0.5 metres into the gully sides and 0.5 metres below the original depth of the gully (see Figure 17). This is done to ensure the Peat Dam will be fully keyed-in to the gully and thereby prevent undercutting or dam failure.
- 13.5.7. In the planned location of the Peat Dam wall, the excavator scoops out plugs of peat from the bottom of the gully. These are inverted and placed back into the holes from which they were removed. This is done across the entire width of the gully.
- 13.5.8. The plugs are tamped down using the heel of the excavator bucket to make a water tight seal.
- 13.5.9. Additional plugs of peat are dug systematically from the bottom of the gully and from the surrounding ground within reach of the excavator arm. These plugs are used

to build the Peat Dam. Peat Dams should be constructed up to two metres deep (front to back), where required, in order to ensure its structural integrity.

13.5.10. The finished height of standard peat dams should be slightly above the top of the drainage feature and keyed into adjacent saturated peat beyond its side to facilitate a diffused flow of water across the bog surface outside of the drainage feature. This will reduce the risk of the dams being damaged or undermined.

13.5.11. The whole Peat Dam is then firmed down using the excavator bucket to make a watertight seal. Vegetated turves are then translocated from the surrounding ground to cover the peat dam wall, in order to prevent oxidation and erosion of the peat.

13.5.12. In the locations where peat has been extracted to build the dam or vegetation translocated to cover the dam, re-instatement work is undertaken. This includes re-profiling of the ground and covering bare areas of ground with vegetated turves, to ensure vegetation re-growth and prevent erosion.

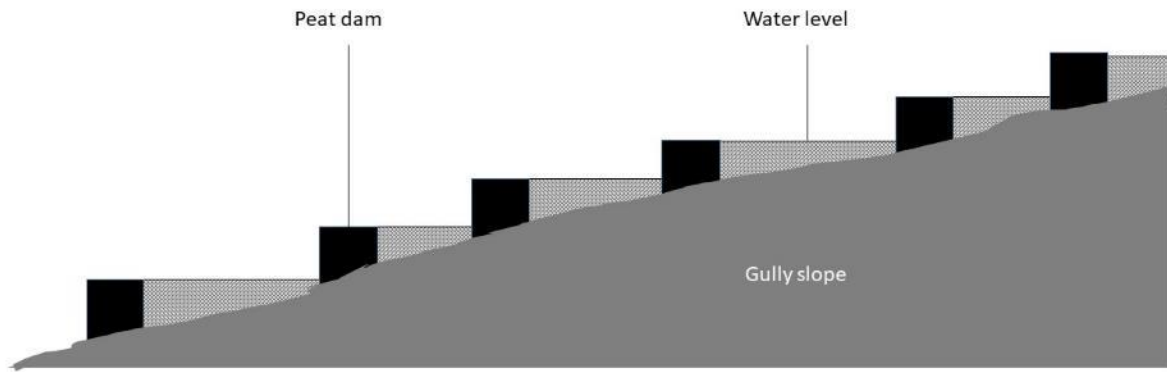

Figure 16 Peat dam spacing

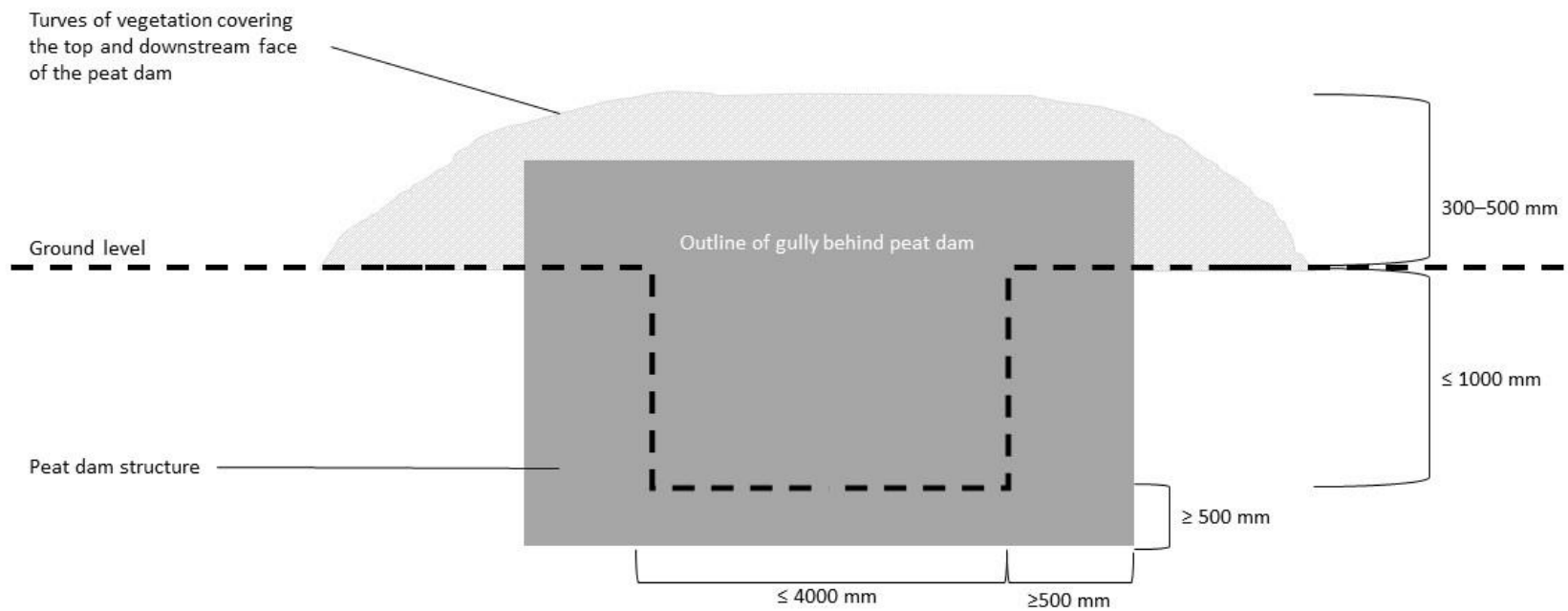

Figure 17 Peat dam construction

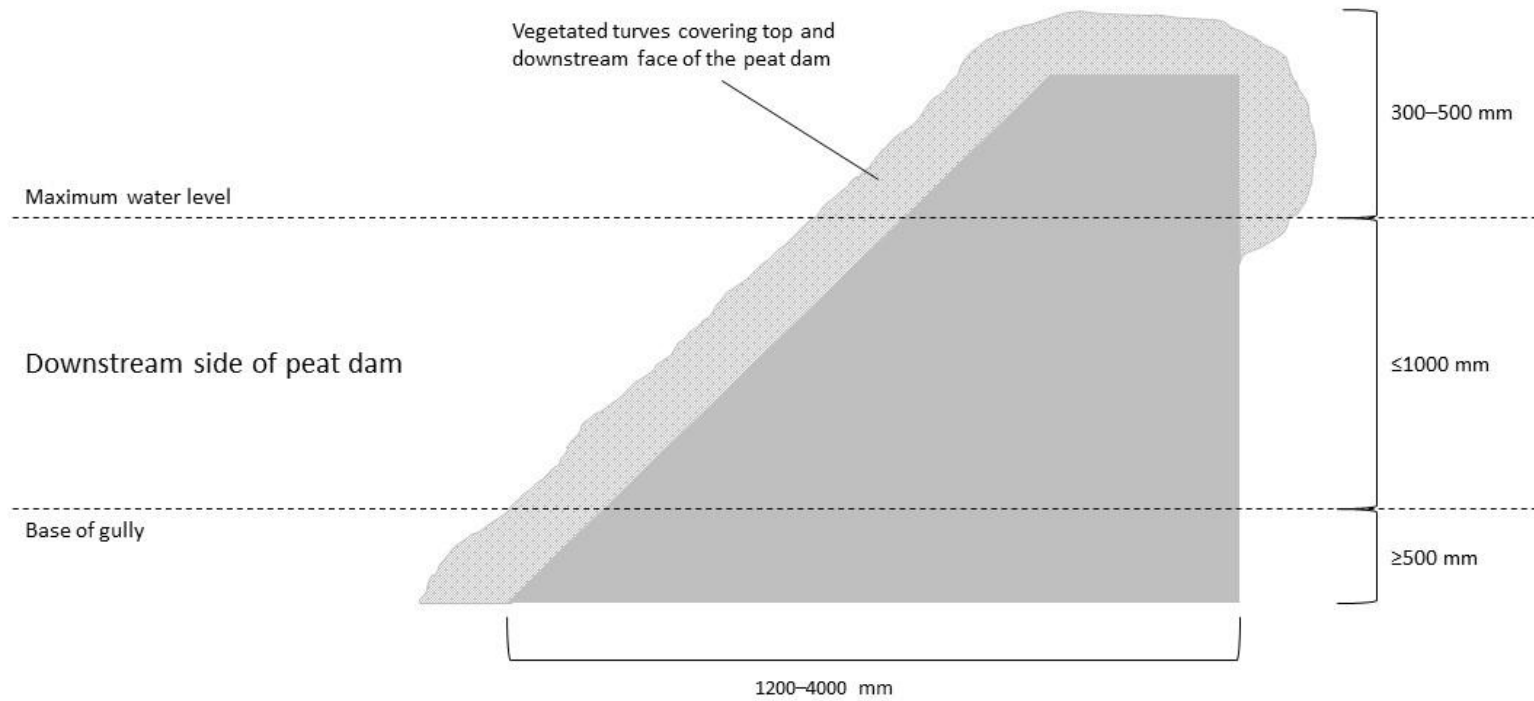

Figure 18 Peat dam construction - cross section

14. Specification for Re-profiling gully systems up to and including 2m high

Where hagg edges and gully sides are steep sided or too steep for most revegetation methods (>45°), they will be reprofiled to create a more stable surface for revegetation. Reprofiling involves carefully pulling back the turf so that the underlying steep peat faces can be reduced to slopes of 30–45°. The desired result is a more stable slope ideally of 30° but up to 45° where a shallower slope is not possible to achieve. The turf should then be pulled back and stretched to cover the bare peat at the break of slope and if there is sufficient positioned at the bottom of the reprofiled slope. Reprofiling is undertaken using low ground pressure excavators. Where there is not enough turf to cover the reprofiled slope, the slope will be revegetated by using materials to further stabilise the peat, following specifications in sections 7 and 9. This is the case for the majority of reprofiled slopes in the MFFP working area.

The angle to which a gully side is reprofiled will be depend on the height of the gully side, reach of the excavator being used, and the presence or absence of evidence of water flow in the gully. Ideally the slope will be reprofiled to as close to 30° as possible depending upon the gully width. Where possible, reprofiling will be undertaken without the toe of the slope extending into water flow paths, however this can be undertaken where necessary.

If turves won during reprofiling don't cover the entire slope, they will be seated to cover the break of slope and also into the toe of the reprofiled slope to stabilise the bare peat, this will be followed up with bare peat restoration as per section 7 and 9. Where there is no evidence of water flow this will be sufficient to stabilise the slope without the need for extra toe protection. See Photo 1 for an example.

Where there is evidence of water flow (e.g. active erosion channel, flattened vegetation, peat/mineral deposits) extra toe protection in the form of stone gully blocks or baffles will be installed where required into gullies to protect the toe of the reprofiled slope from water flow.

Reprofiling of gully sides will follow the process below (see also Figures 19 - 23).

14.1. Gully / hagg Dimensions

14.1.1. In order to reprofile both sides of a gully, the width of the gully should be at least double the height of the slope to be reprofiled. For example, the table below shows the widths of gullies required to reprofile to either 33 ° or 45 ° E.g. To reprofile both sides of a gully 2m high to 45°, the gully should be at least 4m wide at its base if the gully sides are vertical.

Gully depth (m)	33 degrees	45 degrees
	Min. Gully width at base (m)	Min. Gully width at base (m)
≤1m	3.08	2
>1≤2	6.16	4

- 14.1.2. The height of the slope to be reprofiled should be no more than 2m high.
- 14.1.3. Gully sides / hags of one metre or less in height in gullies more than 3m in width should be reprofiled to as close to 30-35° as possible.
- 14.1.4. Gullies / hags up to 2m in height will be reprofiled to as close to 30° as possible depending upon the width but not more than 45° and where possible avoiding too much of the toe of the restored slope being in a water flow path. Where this happens, additional toe protection will be required.

14.2. Methodology

- 14.2.1. This methodology covers gullies up to a maximum of 2m in height where the gully profile allows the desired slope to be achieved using the reach of the excavator.
- 14.2.2. Using an excavator bucket, vegetation situated on the top of the gully (and any overhanging vegetation) will be peeled back far enough to expose enough peat to allow the gully side to be reprofiled to a sloping bank. The driver of the excavator will keep the root structure of the resulting turf intact, in order to increase the survival rate of the vegetation.
- 14.2.3. The exposed bare peat that forms the sides of the gully is then reprofiled to create a 30–45° sloping bank that will support vegetation growth. Ideally the slope should be as close to 30 ° as possible.
- 14.2.4. The vegetation turf that was previously removed from the top of the gully (or the overhanging vegetation) is stretched and placed over the break of slope and if possible the bottom of the reprofiled slope and firmed down with the excavator bucket. Where there is insufficient vegetation to cover the reprofiled slope, heather brash and lime, seed and fertiliser should be spread. Heather brash will be spread as soon as possible, ideally within 2 weeks, or otherwise no more than a month after the reprofiling to prevent bare peat washing off the slopes. Please see section 7 and 9 for bare peat revegetation specification.
- 14.2.5. The top of the stone dam/baffle must remain a minimum of 20cm above the toe of the reprofiled slope to allow for sediment capture. If the stone dam/baffle is below this level after reprofiling, the stone dam will be reconfigured and more stone added if necessary. If one dam does fill immediately with sediment, the chain of stone dams / baffles down the systems is designed to capture the remaining sediment.

14.3. Protecting the toe of the reprofiled slope

- 14.3.1. The toe of all reprofiled slopes is protected by the translocated turfs from step 14.2.4, which are placed at the bottom of the reprofiled slope. This turf helps protect from erosion and stabilises the bottom of the slope immediately. See Photo 1.
- 14.3.2. Where there are signs of water flow (including signs of flattened vegetation, peat/mineral deposits), stone sediment traps will be installed before reprofiling. Where there is no evidence of water, if required heather bales or coir logs may also be used to trap sediment at the toe of a reprofiled slope.

14.3.3. Where the gully is <4m wide, a stone dam will be used as per section 12. Stone dams should be placed every 6-8m along the gully base.

14.3.4. Where the gully is ≥ 4 m wide or a hagg, stone baffles will be used as per Figure 23. Stone baffles should be placed every 6-8m along the gully base. See photo 2.

14.3.5. The stone sediment traps will allow for at least 20cm of sediment to be trapped whilst reprofiled slopes are revegetating.



Photo 1 Photo showing translocated turf from the drip edge, now protecting the toe of the newly reprofiled slope. This gully is 2m high and has no evidence of water flow, therefore does not need extra toe protection.



Photo 2 Stone baffles used to slow down the flow of water and protect the toe of the reprofiled slope. This gully is 2m high.

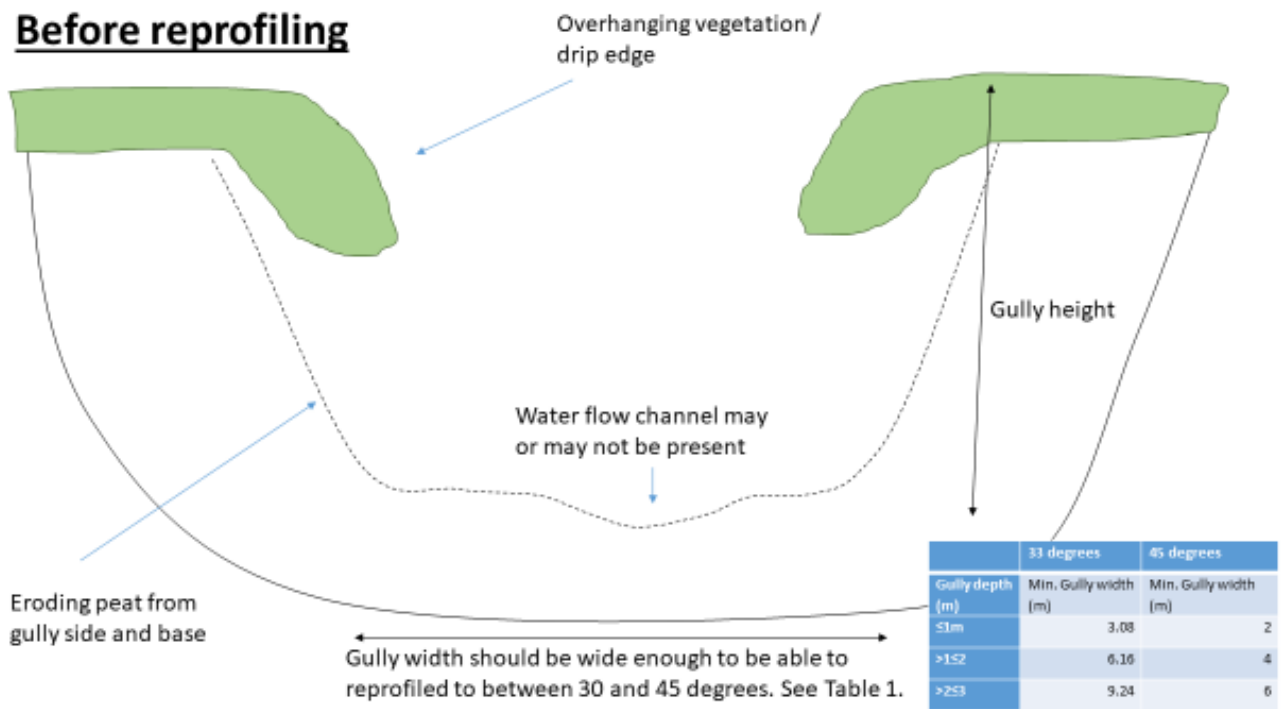

Figure 19 Diagram of a gully before reprofiling

After reprofiling - Here there is enough turf to stretch over the entire slope, and no need for brash, lime, seed and fertiliser

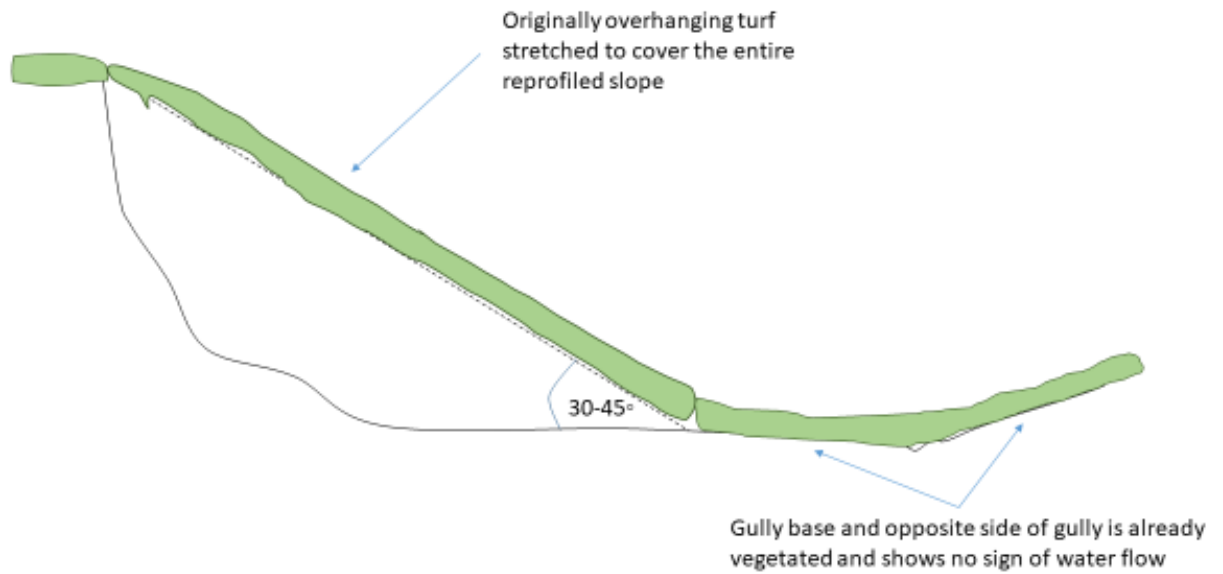

Figure 20 After reprofiling - turf stretched across the entire slope

After reprofiling - Only reprofiling one side of gully and no evidence of water flow, therefore standard toe protection using turves is sufficient

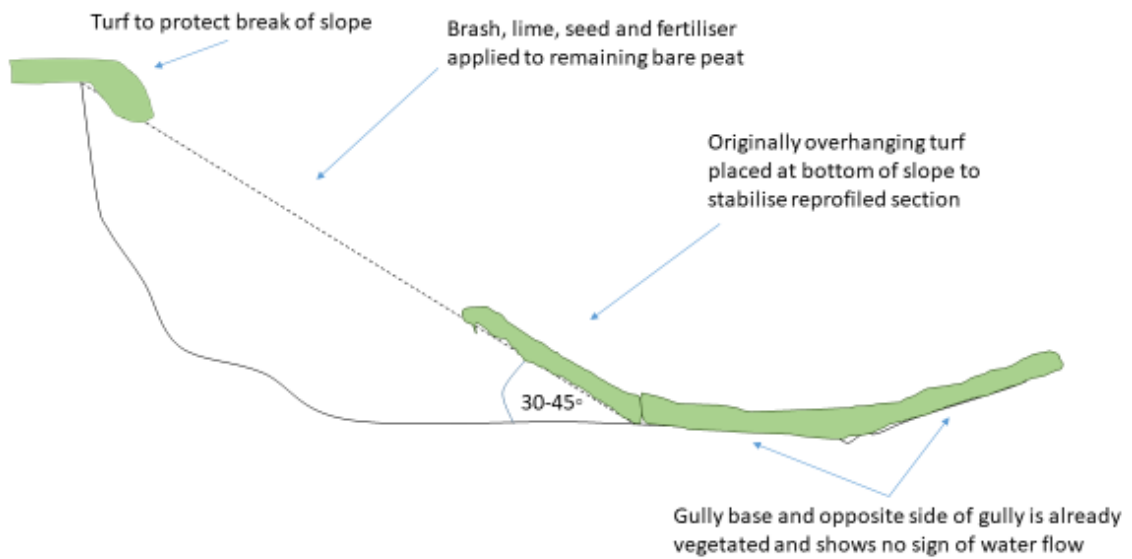

Figure 21 After reprofiling - not enough turf to stretch across entire slope

After reprofiling - Reprofiling both sides of slope and evidence of water flow therefore stone dams installed

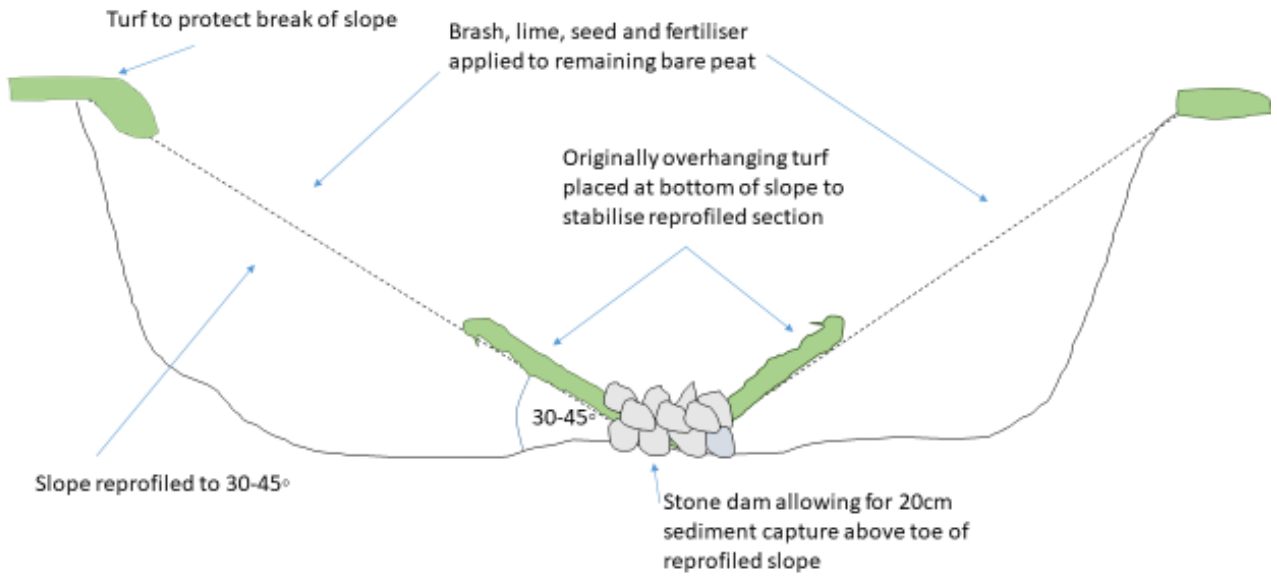

Figure 22 After reprofiling - both sides reprofiled and stone dam constructed

After reprofiling - Very wide gully (>4m), using baffles instead of dams

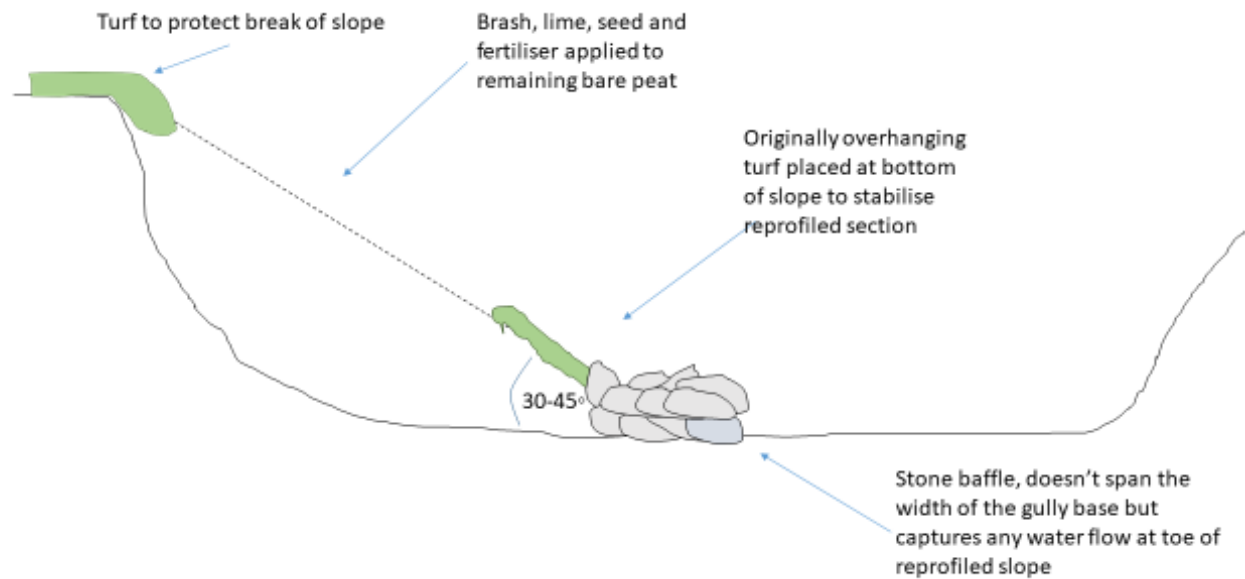

Figure 23 After reprofiling - stone baffle

15. Specification for Reprofilng slopes over 2m high but less than 3m

The reprofiling of slopes over 2m in height is currently not consented within the National Trust Guiding Principles. This is subject to a separate consent and is in discussion with the local Natural England team.

Gullies over 3m in height will not be reprofiled.

Figures 30 to 34 are also applicable to slopes over 2m high and below 3m.

In order to reprofile gullies over 2m in height, the gully must be sufficiently wide (twice the height of the gully), the gully may be narrower if only one side of the gully is being reprofiled. The angle to which a gully side is reprofiled will be depend on the height of the gully side, reach of the excavator being used, and the presence or absence of evidence of water flow in the gully. Ideally the slope will be reprofiled to as close to 45° if possible depending upon the gully width. The Table below shows examples of the angles possible with varying width. Where possible, reprofiling will be undertaken without the toe of the slope extending into water flow paths, however this can be undertaken where necessary. Where this occurs the toe of the slope will be protected by stone dams / baffles.

Gully depth (m)	33 degrees		45 degrees	
	Min. Gully width at base (m)		Min. Gully width at base(m)	
≤1m	3.08		2	
>1≤2	6.16		4	
>2≤3	9.24		6	

For larger gullies between 2m and 3m high, and less than 4-6m wide, it may not be possible to reprofile the slope to 45° without the toe of the slope extending into the central gully, this will be acceptable in instances where only one side of the gully is being reprofiled, or there is no evidence of water flow (active erosion channel, flattened vegetation, peat/mineral deposits). If there is evidence of water flow and the slope cannot be reprofiled to 45°, the slope should only be reprofiled to a slope greater than 45° and less than 60° if there is sufficient vegetation to cover the slope without the need for bare peat revegetation. See photo 3.



Photo 3 A 3m high slope reprofiled to greater than 45 degrees. There was sufficient existing vegetation to cover the reprofiled slope without the need for extensive bare peat restoration.

15.1. Methodology

- 15.1.1. Using an excavator bucket, vegetation situated on the top of the gully (and any overhanging vegetation) will be peeled back far enough to expose enough peat to allow the gully side to be reprofiled to a sloping bank. The driver of the excavator will keep the root structure of the resulting turf intact, in order to increase the survival rate of the vegetation.
- 15.1.2. The exposed bare peat that forms the sides of the gully is then reprofiled to create a as close to 45° sloping bank as possible that will support vegetation growth.
- 15.1.3. The vegetation turf that was previously removed from the top of the gully (or the overhanging vegetation) is stretched and placed over the break of slope and if possible the bottom of the reprofiled slope and firmed down with the excavator bucket. Where there is insufficient vegetation to cover the reprofiled slope, heather brash and lime, seed and fertiliser should be spread. Heather brash will be spread as soon as possible, ideally within 2 weeks, or otherwise no more than a month after the reprofiling to prevent bare peat washing off the slopes. Please see section 7 and 9 for bare peat revegetation specification.
- 15.1.4. The top of the stone dam/baffle must remain a minimum of 20cm above the toe of the reprofiled slope to allow for sediment capture. If the stone dam/baffle is below this level after reprofiling, the stone dam will be reconfigured. If one dam does fill immediately with sediment, the chain of stone dams / baffles down the systems is designed to capture the remaining sediment.

15.2. Protecting the toe of the reprofiled slope

- 15.2.1. The toe of all reprofiled slopes is protected by the translocated turfs from step 18.1.3, which are placed at the bottom of the reprofiled slope. This turf helps protect from erosion and stabilises the bottom of the slope immediately. See Photo 1.
- 15.2.2. Where there are signs of water flow (including signs of flattened vegetation, peat/mineral deposits), stone sediment traps will be installed before reprofiling. Where there is no evidence of water, if required heather bales or coir logs may also be used to trap sediment at the toe of a reprofiled slope.
- 15.2.3. Where the gully is <4m wide, a stone dam will be used as per section 17. Stone dams should be placed every 6-8m along the gully base.
- 15.2.4. Where the gully is ≥ 4 m wide or a hagg, stone baffles will be used as per Figure 2.3. Stone baffles should be placed every 6-8m along the gully base. See photo 2.
- 15.2.5. The stone sediment traps will allow for at least 20cm of sediment to be trapped whilst reprofiled slopes are revegetating.

16. *Sphagnum* and Dwarf Shrub Specification

Sphagnum moss plug plants will be planted into heather cuts and other suitable habitat present on the site and according to the methodology given below. The purpose of introducing *Sphagnum* is to initiate wider colonisation by the mosses in areas lacking *Sphagnum*, and to accelerate its recovery in places where it is present.

Dwarf shrub plug planting or seeding will be used in areas requiring diversification of for bare peat revegetation.

16.1. 18.1 Environmental Mitigations

- 16.1.1. Planting will be done by small teams of staff on foot (4-6 people).
- 16.1.2. *Sphagnum* plugs will be carried on foot on to the sites each day and any waste materials carried off at the end of each day.
- 16.1.3. Dwarf shrub plugs may be airlifted onto site by helicopter.
- 16.1.4. Plugs will be planted into suitable habitat to ensure they have the best chance of thriving.
- 16.1.5. *Sphagnum* plugs used will have been propagated in greenhouses to be free from pest, disease and unwanted species. Some or all of the following species will be included in the plugs:
 - *S. capillifolium*
 - *S. papillosum*
 - *S. palustre*
 - *S. magellanicum*
 - *S. subnitens*
 - *S. fallax*
 - *S. cuspidatum*
 - *S. fimbriatum*
 - *S. squarrosum*
 - *S. tenellum*
 - *S. denticulatum*

Dwarf shrub plugs will be all or some of the following species;

- Common cotton grass
- Hare's tail Cotton grass
- Bilberry
- Cross leaved heath
- Crowberry
- Cloudberry

Each Plug Plant will conform to the following requirements:

- Of local provenance, i.e. propagated from material collected from within the Peak District / South Pennines SAC.
- Grown in medium with:
 - Zero peat content
 - a pH of between 3 and 4; and
 - low nutrients and high metal ions.

16.2. Transporting Plants to the Work Sites

16.2.1. It will be the contractor's responsibility to transport the Plants to the Planting Areas.

16.2.2. Details of permitted transportation of Plants will be detailed in each Works Plan. This may be by foot, helicopter or low ground pressure vehicle.

16.2.3. Each Works Plan will state whether or not ground vehicles are permitted on the Works Site(s). No vehicles (other than helicopters) are permitted on any Work Site unless otherwise permitted by the Nominated Officer.

16.3. Dwarf Shrub Plug Planting Specification

16.3.1. Dwarf Shrub Plug Plants will be planted within the Planting Areas identified on the Work Site Location Maps which will be provided with each Works Plan.

16.3.2. The planting density is approximately one plant per four square metres.

16.3.3. The different types of Plant require planting in specific areas to give the best chance of establishment.

16.3.4. Bilberry & cloudberry will be planted on hagg tops;

16.3.5. Crowberry will be planted at the apex of, and around, slopes; and

16.3.6. Cotton grasses and cross leaved heath should be planted on flatter, wetter areas such as peat pans, behind dams or along the waterline of gullies.

16.3.7. Using a dibber of 45 mm in diameter and 200 mm in length, make a hole in the peat that is 150 mm – 200 mm deep. The hole must be at least this deep to prevent the Plug Plants from being dislodged by frost heave.

16.3.8. Once the hole is made, remove the Plug Plant from the tray and remove the wrapping from the Plug Plant.

16.3.9. Tease the roots out from the compacted Plug Plant.

16.3.10. Place the Plug Plant in the hole. It is important to ensure that the base of the Plug Plant is firmly in contact with the base of the hole to ensure that there is no air gap around the roots.

16.3.11. Once the Plug Plant is firmly in place the peat around the hole should be firmly heeled in round the plant.

16.4. Plug Plant Care Guidelines

Upon delivery the Contractor becomes and remains wholly responsible for the maintenance and condition of the plugs

Storage and care of Plugs;

- Plugs should be kept in a cool, sheltered location with some natural sunlight (not in direct sunlight but also not in the dark)
- Plugs should not be allowed to freeze
- Plugs should be kept moist (whitening of plant branches indicates drying out)
- Plugs should only be watered with rainwater (tap water will kill them)
- Plugs should be stored so they are not getting squashed by the weight of other Plants on top.
- Plugs should be kept out of reach of animals



Figure 24: Sphagnum bundle of 20 Plugs securely wrapped in either Clingfilm, or in specially designed brown paper wraps. Sphagnum bundle is moist with rainwater and vibrant green.



Figure 25: Dwarf Shrub Plugs supplied with a peat base in plant trays.

Sphagnum Plug Planting Guidelines

Sphagnum Plugs will be delivered in Bundles of 20 Sphagnum Plugs wrapped together in one bundle with cling film or specially designed paper. A bag will contain 20 x Bundles / 200 Plugs.



Figure 26: Sphagnum Bundle of 20 Plugs securely wrapped in clear film. The Bundle is moist and vibrant green.

The bag will show the type of mix of species and name(s) on the bag. This could include:

Moorland Mix – a mix of 11 species (this is the traditional mix that we plant the most) and includes a broad mix of different types of species including both flush and hummock or chunky species.

Chunky Mix – a mix of 5 hummock or chunky species

Single species – Bags containing 200 plugs of a single species, but with different bags containing different species.

Pool Mix – a new mix that will be trialled in spring 2021.

This guide should apply to the planting of ALL types of plugs; irrespective of the type of mix (see the following section for a specific guide to the different mixes).

Planting density

This should be specified by Moors for the Future to the site manager, and **ALL** planters should be aware of the number of plugs that should be planted in an area. Please note, this is a guide and the distance will vary depending on the suitability of the planting area and should not be a rigid rule.

What am I looking for?

- Plant in an area that feels wet underfoot. Areas dominated by Heather, Bilberry and Crowberry can be dry, especially on slightly higher ground.
- Preferably, an area with common cotton grass present (a good indicator of a wet area).
- Small, sheltered spaces (micro-habitats) in-between existing vegetation (newly planted plugs require shelter from the drying wind and sun to get established).
- Where there have been cuts in the vegetation – areas that have had either Heather, Cotton grass or Molinia cut prior to planting. These areas can be planted if the conditions covered here apply.



Figure 27: Ideal vegetation cover for *Sphagnum* sp. wet area with cotton grass providing shelter and light to get through.

What should I avoid?

- Bare peat & peat pans – in contrast to garden plants, *Sphagnum* plugs need shelter from surrounding vegetation to establish, therefore you should never plant in to an area of bare peat, and in peat pans, where the water level regularly changes and sediment can cover the plugs. However, planting into the edges of these areas is acceptable if protected from the sun and wind (therefore the south and western edges can be suitable) and away from any risk of going under water.



Figure 28: Bare Peat and Peat Pans are not appropriate for *Sphagnum* planting



Figure 29: Acceptable to plant in Peat Pans along edges if *Sphagnum* Plugs are protected from sun and wind

- Standing water – only a few species like regular inundation, therefore it is best to avoid planting directly into standing water. The only exception to this is *S. cuspidatum* (see Single Species Guide below) We are currently trialling a ‘Pool Mix’ that will be suitable for planting directly in standing water, such as behind peat dams and bunds.



Figure 30:6 Example of Gully block pool - peat dam on left. Dams can be stone, timber, plastic, heather bale or coir log.

- Gullies with regular running water; only plant on the edges.
- Directly behind gully blocks – these areas are regularly under water and sediment can be an issue. Only plant along the edge of the waterline further away from the block to reduce issues with sediment build-up and raising water levels.
- Top gully edges where the water table is low; these areas will remain very dry during times of little rain.
- An area that is not too densely vegetated; this can be the case with hares-tail cotton grass, heather, bilberry, crowberry and *Molinia* dominated areas, or gullies thick with common cotton grass where there is very little space in-between the vegetation to plant a plug.



Figure 31: Areas of thick vegetation unsuitable for planting

16.5. Planting Method

1. Hold the Bundle the right way up (vivid green capitula on top). Unroll until you get to the first plug. This allows you to look at the size of the plug.
2. Once you have identified a suitable location (micro-habitat), break the surface of the peat and make a hole deep and wide enough to fit in the plug (please note there will be some small variations in size). This can be done using different tools such as a gardener's trowel, dibber, screwdriver or thumb.



Figure 32: Make a hole deep and wide enough to fit in the plug

3. Place/push the plug into the hole leaving only the live capitula heads (vivid green, and sometimes, other colours) sticking out of the ground. Plant the plug so that the capitula heads are as tight together as possible; if too much of the stalks is sticking out, the stems will fall-over with an increased risk of drying out.
4. Pinch or push the peat back to secure the plug into the ground (this is essential to ensure that the plug remains in place).



Figure 33: Plug in hole with peat pushed in to secure plug in place

1. Moorland Mix – a mix of 11 species (this is the traditional mix that we plant the most) and includes a broad mix of different types of species including both flush and hummock or chunky species.

As this is a ‘generalist’ mix, the concept is that no matter where the plug is planted following the guidelines above, one or some of the species present will thrive and grow. This type of mix is ideal for a site with variation in micro-habitats and lacking in any Sphagnum species in general. This is especially the case for large areas of newly revegetated areas of bare peat including a lot of blocked erosion gullies.

2. Chunky Mix – a mix of 5 hummock or chunky species.

This mix is being targeted for areas that are in unfavourable condition, but are largely vegetated and not heavily eroded by gullyng. These areas are more typical and are more hydrologically intact and therefore may have areas of Sphagnum, in particular flush species already present to a degree in the wetter flushes and gullies. In order to move these areas into more-favourable conditions, diversification is key, and in particular, the introduction of Sphagnum species associated with functioning blanket bogs because of their ability to form peat layers.

It is also worth noting that Natural England are moving towards the type of key Sphagnum species present on site, as opposed to general Sphagnum presence when assessing condition.

4. Single species – Bags containing 200 plugs of a single species, but with different bags containing different species.

Flush species e.g. *S. fallax* & *fimbriatum* – prefer wetter, flush areas such as gullies.

Hummock or chunky species e.g. *S. medium* (prev. *magellanicum*), *papillisum*, *capillifolium* – still required wet areas, but can tolerate the drier tops. Suitable for planting in larger, flatter cotton grass dominated areas.

S. cuspidatum – this is a species of Sphagnum that thrives in pools and should always be planted or placed in or on the edge of semi-permanent pools such as behind gully blocks (plastic piling or peat dams).

Pool Mix – We are about to trial a mix consisting of *S. cuspidatum* & *S. denticulatum* and *S. fallax*. These are species that thrive in pools and on land and can be planted on to the edge of –semi-permanent pools behind gully blocks.